



Precision Built Solutions™

VT SERIES FRYER 828 CONTROL

MAINTENANCE MANUAL



DESIGNED, ENGINEERED
& ASSEMBLED IN USA

TABLE OF CONTENTS

1.0 - SAFETY INFORMATION

General Safety	3
1.01 Mechanical Safety	4
1.02 Electrical Safety	5

2.0 - BASIC INSTALLATION

2.1 WHERE TO PLACE YOUR MACHINE

2.11 Foundation	6
2.12 Environmental Conditions	6

2.2 UNLOADING YOUR MACHINE 6

2.3 RECEIVING YOUR MACHINE 6

2.4 UNPACK AND PLACE YOUR MACHINE 7

2.5 PRIOR TO THE ARRIVAL OF THE TECHNICIAN

2.51 Installation Safety Instructions	7
2.52 Cleaning & Lubricating Machine	7
2.53 Line Voltage Check	7
2.54 Electrical Precautions	8

2.6 LEVELING THE MACHINE

2.61 Leveling Procedure	9
-------------------------------	---

3.0 - GENERAL INFORMATION

3.1 MAINTENANCE SCHEDULE CHART 10

3.2 MACHINE COMPONENTS

3.21 Axis Lubrication System	11
3.22 Electrical System	11
3.23 Pneumatic System	12
3.24 Spindle	12
3.25 Flood Coolant System	13

3.3 BASIC MACHINE PROCEDURES

3.31 Set Axis Home Position	14
3.32 Check Axis Backlash	15
3.33 Adjusting Backlash Compensation	15
3.34 C axis encoder adjustment	16
3.35 Check Spindle Drive Belt	17

4.0 - 828 CONTROL

4.1 ACCESSING MACHINE PARAMETERS 18

4.2 ACCESSING THE SOFTWARE VERSION..... 18

4.3 REVERT TO THE FACTORY SET PASSWORD 18

4.4 ADJUSTING INPUT VOLTAGE PARAMETERS 19

4.5 M-CODES 20

4.6 ALARMS

4.61 Siemens Alarms	21
4.62 Fryer PLC Alarms and Descriptions	21
4.63 Clearing an Alarm	22

4.7 WORKING WITH FILES

4.71 File Types	22
4.72 Back-Up A 828 Archive File to A USB Stick	22

4.73 Reloading an Archive File	23
4.74 Backing Up Tool Data on the 828 Control	23
4.8 ADDING A SOFTWARE OPTION TO AN 828 CONTROL	24
4.9 SET UP NETWORK DRIVE IN AN 828	26
5.0 - TURRET	
5.1 ALIGNING THE TURRET	28
5.2 DIPLOMATIC ERROR ALARM CODES	30
6.0 - DRAWINGS AND PARTS LIST	
6.1 828 CONTROL ELECTRICAL PANEL LAYOUT & PARTS LIST	32
6.2 828 FRONT CONSOLE LAYOUT & PARTS LIST	34
6.3 BASE CASTING ASSEMBLY DRAWING & PARTS LIST	35
6.4 SADDLE DRAWING & PARTS LIST	37
6.5 COLUMN DRAWING & PARTS LIST	38
6.6 RAM DRAWING & PARTS LIST	40
6.7 HEADSTOCK DRAWING & PARTS LIST	41
6.8 OIL TANK DRAWING & PARTS LIST	43
6.9 SPINDLE MOTOR DRAWING & PARTS LIST	44
6.10 SCALE MOUNT DRAWING & PARTS LIST	45
6.11 COOLANT TANK DRAWING & PARTS LIST	46
6.12 SHEET METAL ASSEMBLY DRAWING & PARTS LIST	47

SAFETY INFORMATION- LATHES

READ BEFORE INSTALLING OR OPERATING

**NOTE: THIS MACHINE IS AUTOMATICALLY CONTROLLED
AND MAY START AT ANY TIME.**



All CNC machines contain hazards from rotating parts, belts and pulleys, high voltage electricity, noise, and compressed air. When using CNC machines and their components, basic safety precautions must always be followed to reduce the risk of personal injury and mechanical damage.

It is the machine owner's responsibility to make sure all personnel who are involved in installation and operation of this machine are thoroughly acquainted with the procedures and safety instructions provided herein *BEFORE* they perform any actual work.

Only Fryer factory-trained service personnel should troubleshoot and repair the equipment.

Do not modify or alter this equipment in any way without first consulting Fryer Machine. Any modification or alteration of could lead to personal injury and/or mechanical damage and/or void your warranty.



EMERGENCY STOP (E-STOP) BUTTON

PRESSING THE EMERGENCY STOP BUTTON WILL INSTANTLY STOP ALL MOTION OF THE MACHINE, THE SERVO MOTORS, THE TOOL CHANGER, AND THE COOLANT PUMP.

1. Use the emergency stop button to stop all machine motion in the event of an emergency.
2. Use the feed hold button to stop axis movement during normal operation.
3. Before operating switches, always check that they are the right ones.
4. Do not change parameters, voltages and other electrical settings unless directed by an authorized service technician. If such changes are unavoidable follow the directions provided by the technician carefully.
5. The best defense against injuries on a turning machine is to be alert. Never initiate a machine function unless you completely understand what the function will cause the machine to do.

6. Keep machine and area around it clean and well lighted. Never allow chips, coolant, or oil to remain on the floor. Do not leave loose objects on or around machine.
7. Use appropriate eye and ear protection while operating the machine. ANSI-approved impact safety goggles and OSHA-approved ear protection are recommended to reduce the risks of sight damage and hearing loss.
8. Keep all loose clothing, hair, jewelry away from the machine and from contacting the spindle
9. Gloves are easily caught in moving parts. Take them off before turning on the machine.
10. Always wear safety shoes with steel toes and oil-resistant soles.
11. Do not paint, alter, deface, or remove any warning plates from the machine. Replacement plates are available from Fryer Machine Systems.
12. Keep flammable liquids and materials away from the work area and hot chips.
13. Coolant and oils can make surfaces on the machine slippery. They can also present an electrical hazard if the machine has power on. Therefore, do not stand on any part of the machine at any time.
14. Keep material in the spindle from extending beyond the rear edge of the spindle.
15. Check for damaged parts and tools before operating the machine. Any part of a tool that is damaged should be properly repaired or replaced. Do not operate the machine if any component does not appear to be functioning correctly.
16. Improperly clamped parts machined at high speeds/feeds may be ejected and puncture the safety door. Machining oversized or marginally clamped parts is not safe.
17. To avoid turret damage, ensure that tools are properly aligned when loading tools and that boring bars and facing tools do not protrude behind the back of the faceplate.
18. Windows must be replaced immediately if damaged or severely scratched – contact the factory for replacement panels.
19. Do not attempt to operate the machine before all of the installation instructions have been completed.
20. Be sure to review the Maintenance section of this manual for instructions to keep your machine running properly.

10.1 Mechanical Safety

1. Always press emergency stop when the machine is not in use.
2. Never operate the machine with any cover or shield open or removed.
3. Never reach into the work area when the spindle is turning or if the machine is in automatic mode.
4. Put the machine in manual mode and be sure last programmed function has been completed before reaching inside of the work area.
5. The functions of the machine make it impossible to eliminate all pinch points. Be particularly aware of the following pinch points:
 - a. Spindle and chuck rotation
 - b. Indexing of turret and tools
 - c. Carriage and cross-slide movement
 - d. Tailstock movement, both quill and body
6. Do not operate machine without axis motor covers or axis way covers in place.
7. Report any loose, worn, or broken parts to your supervisor. The same action should be taken if any unusual noise or machine action occurs.

8. The electric components are protected from normal moisture resulting from humidity, use of water base soluble, such as coolant, etc. **DO NOT**, however, use water hose to clean the machine or the area around it.
9. Never touch a machine control device or electrical component when your hand is wet.
10. Never clean up chips while the machine is running or is in automatic mode.
11. Do not manually deburr workpieces being rotated under power.
12. At the end of the workday the machine should be placed in "EMERGENCY STOP MODE"
13. When restarting a machine after it has been shut down always assume it has been altered. Recheck all phases of the job as though you were running the first piece.
14. Never touch spindle start or spindle jog control until hands, feet, and body are well clear of the work area.
15. Never extend an unsupported bar out of the rear of the spindle or hydraulic cylinder. Doing so can cause the bar to bend or break resulting in damage or injury.
16. If your turning machine has a bar feeder interfaced to it keep yourself and others away from the exit end of the bar feeder when the machine is running.

1.02 Electrical Safety

1. **WARNING:** Electrical enclosures contain high voltage. Disconnect equipment from power source before opening cabinets.
2. Before replacing a fuse, switch off the machine.
3. **Immediately turn off power if:**
 - Power problems develop
 - In the event of electrical storms.
 - Ambient temperatures exceed 105 degrees Fahrenheit (40 degrees C)
4. The electrical power must meet the specifications in this manual. Attempting to run the machine from any other source can cause severe damage and will void the warranty.
5. The electrical panel should be closed and locked at all times except during service
6. When the main circuit breaker is on, there is high voltage throughout the electrical panel and some components operate at high temperatures. Therefore, extreme caution is required.
7. Do not reset a circuit breaker until the reason for the fault is investigated.
8. Never service the machine with the power connected.

2.0 BASIC INSTALLATION

2.1 WHERE TO PLACE YOUR MACHINE

Thank you for choosing Fryer Machine Systems. You have purchased a high quality, custom crafted machine tool designed and built to provide years of trouble-free service. To ensure that your machine is properly installed we ask that you review the following information prior to the shipment of your machine.

2.11 Foundation

Your foundation must be a minimum 6"(150mm) thick concrete slab floor and should be placed on a single slab with no seams. Be sure to leave space around the machine for leveling components and access to the electrical cabinet.

If your floor does not meet these specifications, contact the factory for further recommendations.

Install the machine on the first or second floor. Take the stress of ceiling and foundation into careful consideration to ensure that the machine load can be offset.

2.12 Environmental Conditions

Generally, the machine will be installed in the following conditions. However, these may change over a period of time or in response to seasonal changes.

- Supply voltage: +/- 10% of voltage listed on serial number tag.
- Source frequency: ± 2 Hz of frequency listed on serial number tag
- Temperature effects dimensional accuracy, therefore, ambient temperatures should not exceed 105 degrees Fahrenheit. Also avoid exposing the machine to direct sunlight or heat rays which can change the environmental temperature.
- Relative Humidity: Less than 80% (Temperature changes should not cause condensation)
- Atmosphere: Free from excessive dust, fumes, corrosive gases, and salt
- Avoid exposing the machine to abnormal vibration.

2.2 UNLOADING YOUR MACHINE

Fryer machines are shipped on skids designed for forklift offloading. Be sure your forklift is rated for the proper weight of the machine.

Note: If you are using a crane for offloading, please contact the factory in advance for instructions as damage can occur if supported in the wrong locations.

2.3 RECEIVING YOUR MACHINE

NOTE: If you have a door that is less than 8' wide x 10' high, please contact the factory prior to shipment so that we can make sure your machine is packaged to fit into your door openings.

1. Fryer machines are carefully packed to avoid damage in transit; however, we ask that you **UNWRAP AND INSPECT YOUR MACHINE AS THOROUGHLY AS POSSIBLE PRIOR TO SIGNING THE BILL OF LADING.** If a digital camera is available, pictures should be taken before the machine is moved further. Pictures should be sent to service@fryermachine.com.
2. Place the machine in its location and complete inspection. If there is any damage to your machine, Fryer should be notified immediately. This will enable us to provide replacement parts before the service technician arrives install the machine.
3. If you have any questions about any of these installation instructions or other questions about your new Fryer Machine Systems machine, please call the Fryer Service Department and one of our trained technical staff will be happy to assist you.

2.4 UNPACK AND PLACE YOUR MACHINE

To make certain that your machine installation goes smoothly, it is important that the following items are completed **prior** to the arrival of the Fryer authorized service technician. This will ensure that our technician is able to provide you with the maximum amount of training during his allocated time with you.

1. Have your rigger move the machine to the operating location, remove it from the skid and install on ALL leveling pads.
2. Remove all packaging material and thoroughly clean the machine and inspect for hidden damage.
3. Remove all large assemblies from skids and stage next to machine to facilitate ease of assembly.
4. Install leveling pads and level machine. Level with a precision level, using the leveling screws and pads provided with the machine.

2.5 PRIOR TO THE ARRIVAL OF THE TECHNICIAN

2.51 Installation Safety Instructions

Initial start-up of the machine must be performed by a Fryer Machine Systems authorized service technician.

2.52 Cleaning & Lubricating Machine

All protective coatings (cosmoline) must be removed before using the machine.

Be cautious when selecting a suitable cleaning agent. Paraffin applied with a clean brush will soften the protective coating. The protective coating can then be removed with clean rags.

- WD-40 or a similar product is recommended for cleaning the machine. Do not use gasoline or any other flammable solution to clean the machine.
- Clean all exposed ways of the bed and saddle.

2.53 Line Voltage Check

Line voltage must be $\pm 10\%$ of the voltage listed on the serial number tag.

**INITIAL POWER-UP SHOULD ONLY BE PERFORMED BY
A FRYER TECHNICIAN OR FACTORY AUTHORIZED
REPRESENTATIVE.**

2.54 Electrical Precautions

Wiring

1. Ensure that all local electrical codes are met.
2. Do not connect to the power distribution panel any power cables for devices that can cause line noise, such as welders and high frequency quenching machines.

Grounding

You should always refer to your local electrical code to be sure you are grounding to code. Generally, use a grounding wire with a cross section of more than 14 mm and a resistance to ground of less than 100 ohms. This wire size should be greater than AWG (American Wire Gauge) No. 5 and SWG (British Legal Standard Wire Gauge) No.6.

Generally, the machine should be grounded to a separate grounding rod. If an independent ground cannot be provided for the machine, prepare the ground connection as follows:

1. Connect a single conductor to its own grounding terminal. This will avoid possible serious accidents resulting from ground currents that might otherwise flow in the NC machine if a peripheral device should malfunction.
2. Be careful when using concrete reinforcing rods as grounding points. These reinforcing rods often are used to ground equipment because they usually offer a resistance to ground of less than 100 ohms. In doing so, make the connection as follows: (This also applies to connecting ground wires to regular grounding terminals)
3. Do not use the same grounding reinforcing rod or grounding terminal for other devices since this could lead to line noise such as produced electric welders and high frequency quenching machines.
4. Use a grounding terminal with an adequate electrical performance rating and which is durable.
5. A separate grounding wire should be used, one whose length is as short as possible.
6. Check the resistance to ground by actual measurement.
7. This should measure less than 100 ohms if the single device is connected to its own grounding rod.

Desirable Independent Grounding: Earth resistance: Less than 100 ohms **Common Grounds:**

Resistance to ground = $100 / \text{the number of devices connected to the grounding } (\Omega)$

NEVER GROUND EQUIPMENT IN SERIES!

Connection of Power Line

NOTE: Electrical installation should only be completed by a qualified electrician.

1. Make sure that the incoming power is compatible with the requirements of the machine tool (voltage, amperage, phasing). All this information can be found on the machine's serial number tag.
2. Power wires, grounding and over-voltage protection should comply with the local electrical code.
3. **DO NOT** connect if the incoming power is different from the power requirements of the machine. Contact a qualified electrician.

2.6 LEVELING THE MACHINE

Before attempting to use the machine, it will be necessary to accurately level it.

- 1.Screw the leveling bolts (with nut) into the holes in the base of the machine. Set a leveling pad under.
- 2.Please prepare the following tools to adjust machine level:
- 3.Two spirit levels (0.0005"/ft. or 0.013mm/1000mm accuracy)
- 4.Two adjustable wrenches
- 5.Clean the bed way and cross slide surfaces thoroughly and set one of the spirit levels on the flat bed way in the longitudinal direction, and the other on the cross slide, perpendicular to the first (if there is only one level available, then use it on both directions alternately).
- 6.Move the machine in the Z-Axis as close to the head stock as possible and center the cross slide in the X-Axis. Start using the corresponding leveling feet to get the levels to read zero.
- 7.Now move the machine toward the tail stock slightly and again use the leveling feet to make the levels read zero. Repeat this step for the entire Z-Axis travel.
- 8.Repeat steps 6 & 7 until machine is leveled to within 0.001"/ft. (0.08mm/1000mm) in both directions throughout the entire Z-Axis travel.
- 9.Lock the nuts on the leveling bolts, and re-check to see whether the level of machine is still correct. Repeat as necessary until machine level is obtained with leveling bolts locked.

After initial installation, check the level once a week for the first month, then check monthly thereafter

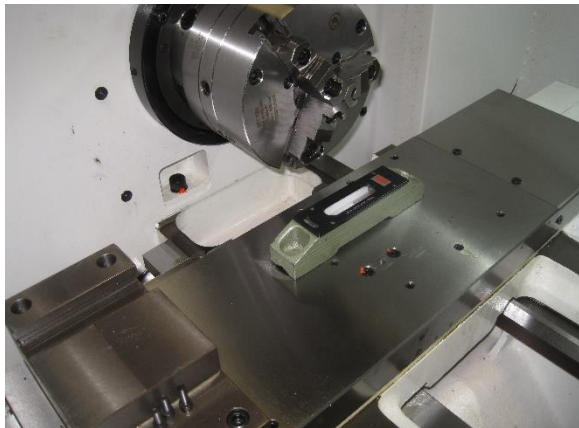

X-AXIS

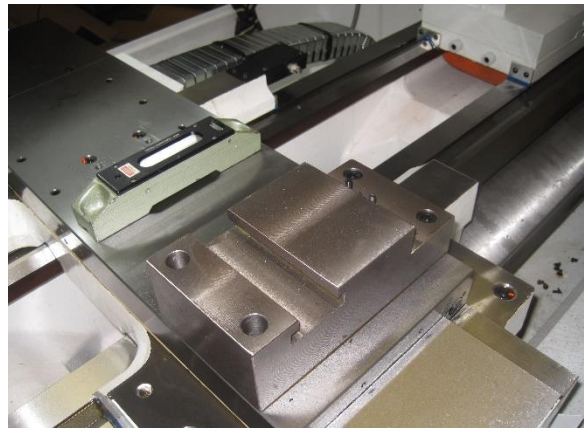

Z-AXIS

3.0 GENERAL INFORMATION

3.1 Maintenance Schedule

CAUTION: Always turn the machine off before performing maintenance.

MAINTENANCE ITEM	RECOMMENDED	Daily	Weekly	As Req'd.	6 Mo	Yearly
Check pressure gages for proper readings	90-125 PSI	X				
Check that machine components and sliding parts have proper lubrication		X				
Check condition of covers for damage or excessive gasket wear		X				
At the end of the day, remove and dispose of chips	Use of brush or vacuum is recommended. Do not use air as it can push chips into ways and ballscrews.	X				
Drain air/water separation			X			
Check wipers for damage			X			
Check coolant level			X			
Check headstock oil level			X			
Check turret oil level (if option is installed)	Mobilub HD Plus 80W90 or equivalent oil		X			
Change coolant	Blasocut BC-40 NF-PL or Equivalent oil			X		
Fill lube pump	Mobil Vactra No. 2, Amoco Waytac No. 68 or Equivalent			X		
Fill air regulator oil for auto shift	Mobil Almo Break-Free Synthetic Air Tool oil (5W-10W) or Equivalent			X		
Check servo cabinet & console fans, clean filters	Frequency should be determined by type of material being cut and number of hours the machine is running.			X		
Check machine level					X	
Check ball screw endplay					X	
Check gibs					X	
Check backlash					X	
Check belt / coupling tension						X
Replace servo cabinet and console filters	Purolator A23465					X
Change headstock (spindle) oil	Mobil DTE ISO VG-32 Hydraulic Oil or Equivalent Oil (VG-22 for ET-18 model)					X
Change hydraulic system oil (if option is installed)	Mobil DTE ISO VG-32 Hydraulic Oil or Equivalent Oil					X
Change turret oil (if option is installed)	Mobilub HD Plus 80W90 or Equivalent oil					X

3.2 MACHINE COMPONENTS

3.21 Axis Lubrication System

- The automatic way lube system is controlled by the PLC in the control. The system only pumps way oil



when the spindle and axes are moving. If there is no machine movement the pump will not pump unnecessary oil. This method greatly reduces way lube usage and keeps oil out of the machine coolant sump and prevents fouling.

- If the machine has been unused for more than 48 hours press the blue pushbutton on the side of the lube tank for approximately 30 seconds to pump oil to the ways. The pressure gage on the tank will indicate if it is working properly.
- If the system detects low way lube it will display the following message in the control: 700040 - WAY OILER PRESSURE FAULT

3.22 Electrical System

- Schematics (1) – The Electrical and Pneumatic Schematics are inside electrical cabinet
- Cabinet Filter Type (2) – Purolator A23465 or equivalent
- Check Filter Interval - Weekly
- Change Filter Interval – As Required (depending on environment)



3.23 Pneumatic System

- Schematic – See Pneumatic Schematic in electrical cabinet (see previous page)



- Pneumatic List / Pressure Settings
 - Main Supply – 90-125 PSI at 5 CFM
 - Air Gun
- Lubrication Requirements – Mobil Almo break free synthetic air tool oil 5W-10W or equivalent
- Check Lubrication Interval – Weekly – Add as needed

3.24 Spindle / Gearbox

Thermal expansion of the machine components can jeopardize machining accuracy. To prevent this condition always warm the machine up.

SPINDLE WARM UP – Warm up the machine by running it for 10 to 20 minutes at about half or one-third the maximum speed in the automatic operation mode.

This automatic operation program should cause each machine component to operate allowing you to check their operation.

SPINDLE DUTY RATING – Follow the duty rating outlined below

- If it is required for the spindle to run continuously (24 hours a day), the spindle must not run above 80% of the maximum RPM.
- If it is required for the spindle to run at maximum RPM, the spindle must not run more than 2 hours straight. After 2 hours of run time at maximum RPM, the spindle must be slowed down to 50% of the maximum RPM for at least 30 minutes before running at the maximum RPM again.

3.25 Flood Coolant System

The flood coolant system consists of a submersible flood pump mounted in the removeable coolant tank. The flood line runs up the back of the column and through the Z-axis cable track into the turret. It comes out by the active tool.

- The sump can be drained for coolant changes by using a wet vaccum.

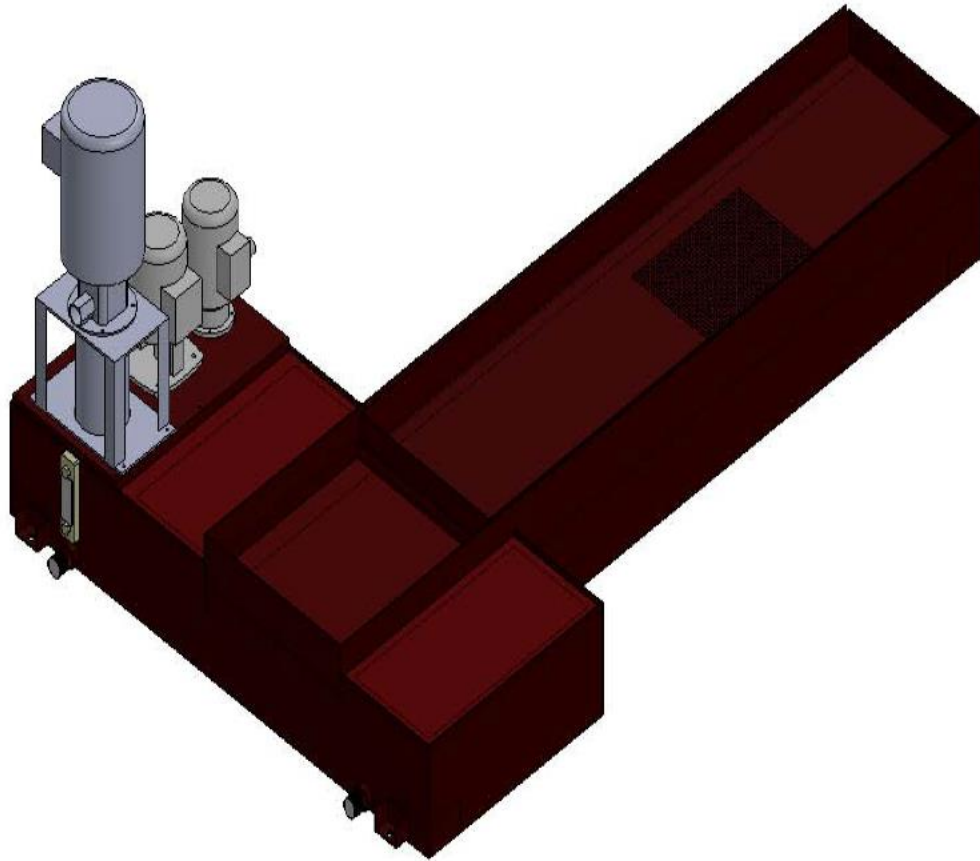

3.3 MACHINE PROCEDURES

3.31 Set Axes Home Positions

PROCEDURE TO BE PERFORMED BY QUALIFIED PERSONNEL ONLY

The 828 control comes standard with absolute encoders which generally do not require homing. However, if you have an issue with the battery or the machine is not turned on for an extended length of time the machine may need to be re-homed according to the following procedure. In addition, if an axis motor is removed or there is an issue with a motor coupling or pulley / belt assembly, one or more axes may need to be re-homed.

•Refer to Section 4.1 for directions to access parameter screens.

1. Press **MENU SELECT**
2. Select **SETUP**
3. Select **MACHINE DATA**
4. Select **AXIS MD**
5. Select **SEARCH**
6. Enter **34210 [0]** in the search field (This will read **ENC_REFP_STATE**)
7. Select **OK**
8. Select the proper axis with the **AXIS + AND AXIS -**
9. Change the parameter **34210 [0] to 0** for an axis with a motor encoder
10. Change the parameters **34210 [0]** and **34210 [1] to 0** for an axis with a scale
11. Press **INPUT**
12. Cycle power to machine leaving it off for a minimum of 30 seconds
13. **Take extreme caution now as the machine can be crashed!**
14. Line up the home markers for all axes that need to be homed
15. Press the **E-STOP** button to turn off the servos
16. Press **MENU SELECT**
17. Select **SETUP**
18. Select **MACHINE DATA**
19. Select **AXIS MD**
20. Select **SEARCH**
21. Enter **34210 [0]** in the search field (This will read **ENC_REFP_STATE**)
22. Select **OK**
23. Select the proper axis with the **AXIS + AND AXIS -**
24. Make sure Parameter **34210 [0]** and **34210 [1]** (if axis has a scale) **are set to 0**. If it is not, it is probable that the wrong axis is selected.
25. Change the parameter **34210 [0] to 1** for an axis with a motor encoder
26. Change the parameters **34210 [0]** and **34210 [1] to 1** for an axis with a scale
27. Press **INPUT**
28. Turn the feed rate override all the way down
29. Pull the **E-Stop** button out
30. Select **RESET**
31. Press **HOME RETURN** (should say Jog Ref at the top of the screen)
32. For a lathe, press **CYCLE START**
33. When done make sure parameter **34210 [0]** shows **2** for all axes (axis with motor encoder)

3.32 Check Axis Backlash

Tools Required: 0.0001" resolution dial indicator, control handwheels handwheel

- Set the indicator along the axis which is being measured. The needle should be in contact with a flat machined surface and the base on a stable, fixed point. See the pictures below which illustrate the setup for the X and Z axes.
- Using the remote handwheel, move the axis in one direction either positive or negative until the indicator is loaded by 0.002".
- Zero the indicator.
- Move the axis in the same direction by 0.005".
- Reverse the direction of the axis by 0.005".
- The additional amount that is needed to reach zero after the 0.005" reverse in direction is the backlash measured.
- This shows the loss of motion in the axis from the ballscrew and linear guide rails. Backlash compensation can be adjusted according to the procedure outlined below in *Section 3.33*.

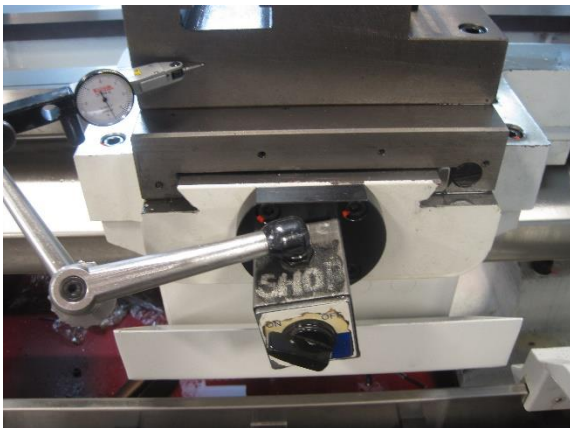

X-AXIS



Z-AXIS

3.33 Adjusting Backlash Compensation

PROCEDURE TO BE PERFORMED BY QUALIFIED PERSONNEL ONLY

Refer to Section 4.1 for directions to access parameter screens.

- Press **MENU SELECT**
- Select **SETUP**
- Select **MACHINE DATA**
- Select **AXIS MD**
- Using **AXIS+ AND AXIS-**, select the correct axis
- Select **SEARCH**
- Enter **32450 [0]**
- Adjust the backlash on each axis
- Select **SET MD ACTIVE (cf)**
- Select **RESET (po)** to reboot the control

3.34 C axis check-encoder alignment

PROCEDURE TO BE PERFORMED BY QUALIFIED PERSONNEL ONLY

If you get a C axis alarm (22051 alarm) check the Encoder ring runout on the spindle. It should not have more than $\pm.0001$ " of runout.

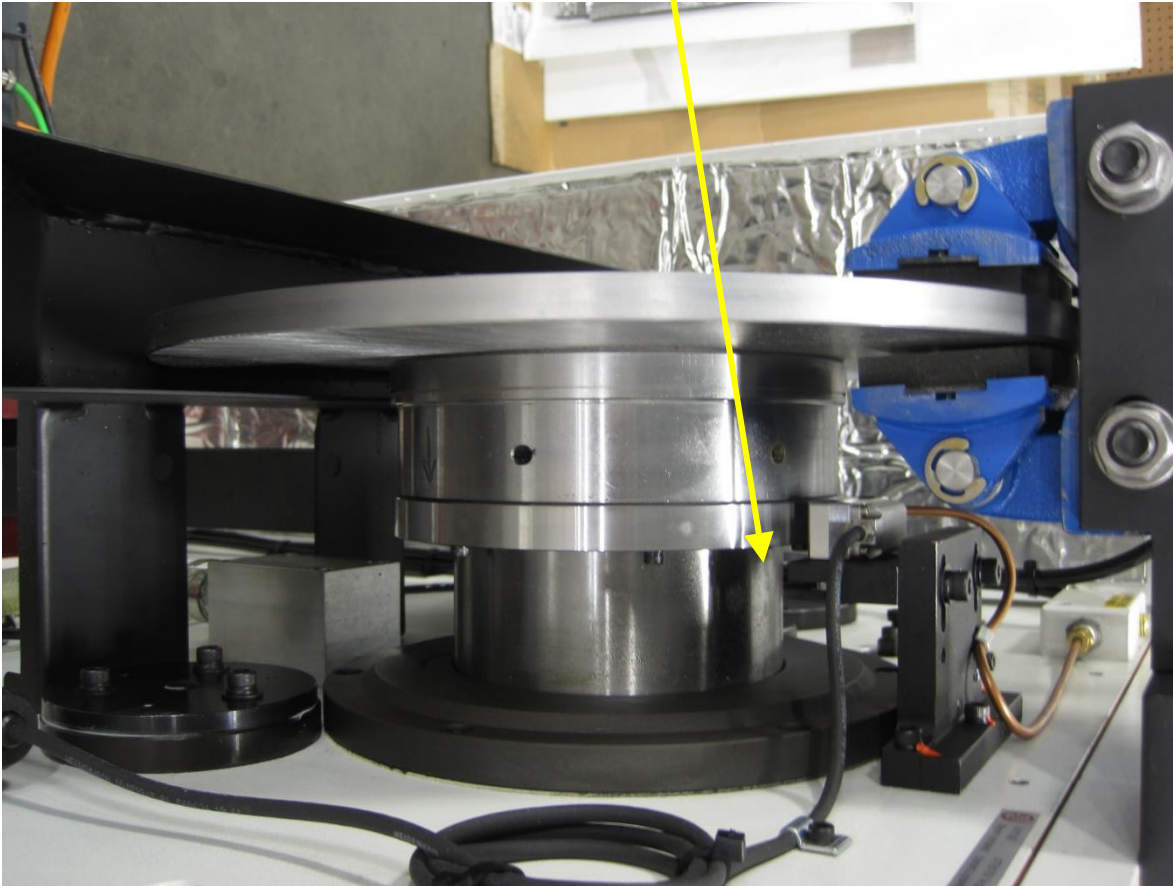

Check the Heidenhain reader head for damage, if not damaged, reset the spacing to .0059" See the HH book that was shipped with the machine in the Folder in the electrical cabinet.



You can cut a .0059" plastic shim , 1/2" wide x 5" long, hold the reader head tight on the ring with the shim in between, tighten the screws, then pull shim out.

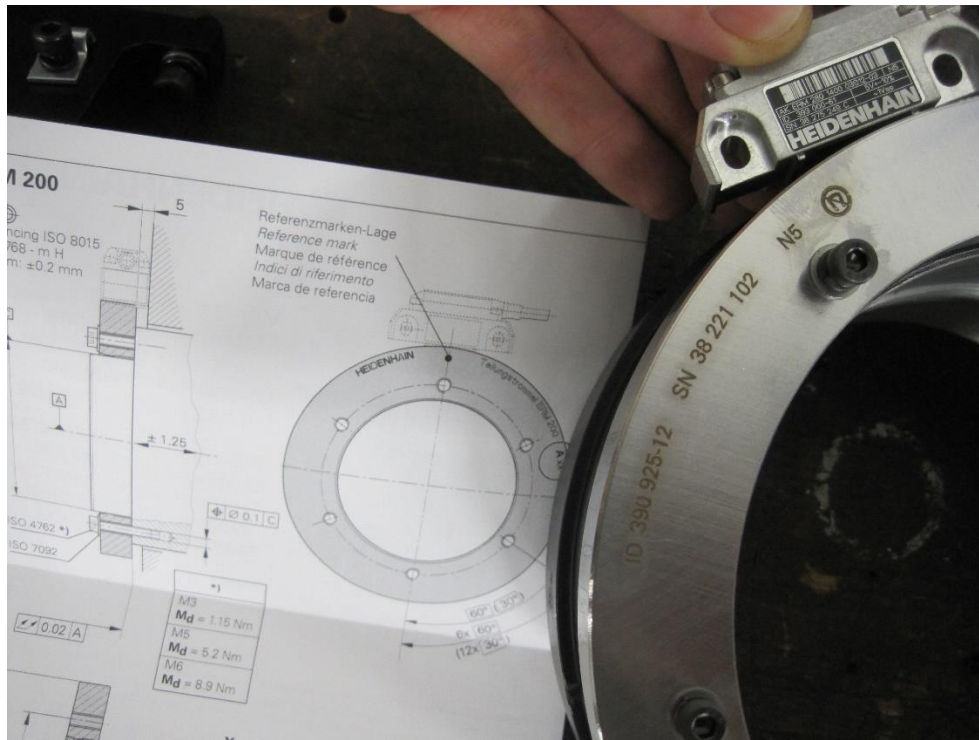

3.35 Check Spindle Motor Belts

- The spindle motor is connected to the spindle gearbox by a timing belt. Belt should be checked for excessive wear and proper tension at least every 6 months.
- Once you have gained access to the belts, inspect them for any visible signs or wear or damage. Once the belts are considered acceptable, check each belt for proper tension.
- Belt tension is adjusted by loosening the slotted motor plate and sliding the motor-plate assembly to tighten or loosen the belt as required. Double check all hardware is properly tightened once the belt tension is correct.
- After the inspection is complete and any adjustments made, re-install the belt covers.

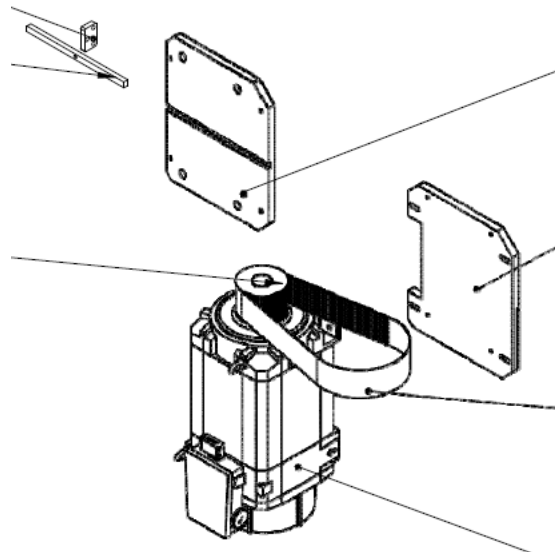

4.0 828 CONTROL

4.1 ACCESSING MACHINE PARAMETERS

PROCEDURE TO BE PERFORMED BY QUALIFIED PERSONNEL ONLY

 **WARNING**

Malfunctions of the machine as a result of incorrect or changed parameter settings

As a result of incorrect or changed parameterization, machines can malfunction, which in turn can lead to injuries or death.

- Protect the parameterization (parameter assignments) against unauthorized access.
- Handle possible malfunctions by taking suitable measures, e.g. emergency stop or emergency off.

1. Press **MENU SELECT**
2. Select **SETUP**
3. Select **MACHINE DATA**
4. Available folders: **GENERAL MD / CHANNEL MD / AXIS MD**

4.2 ACCESSING THE SOFTWARE VERSION

To find out the version of the software you are running on your 828 control:

1. Press **MENU SELECT**
2. Select **DIAGNOSIS**
3. Select **VERSION**
4. The Software Version number is on the first line and will read: **"V###.## + SP ## + HF ##"**

4.3 REVERT TO THE FACTORY SET PASSWORD

PROCEDURE TO BE PERFORMED BY QUALIFIED PERSONNEL ONLY

1. Press **MENU SELECT**
2. Select **SETUP**
3. Select **SET PASSWORD**
4. Enter the password: **SUNRISE**
5. Press **OK**
6. The lower part of the screen should now read "Current Access Level: Manufacturer"

4.4 ADJUSTING INPUT VOLTAGE PARAMETERS

PROCEDURE TO BE PERFORMED BY QUALIFIED PERSONNEL ONLY

The Siemens control will shut itself off if the line voltage is more than 10% different than the voltage set in the control. You must adjust the parameter to match your line voltage to the machine.

The following alarms may occur when this happens:

1. Power 1 overvoltage
2. Axis drive faults
3. DC link voltage overvoltage

The first step to accurately measure your line voltage. There are two ways to do this.

- Measure the incoming line voltage across all three legs with a voltmeter. Average your readings and write down the value.

- OR -

- Read the line voltage from the control, follow the following steps:
 - **MENU SELECT** key
 - **SETUP** key
 - **INFEEED PARAMETER** key
 - Find **r25[0]** = and write down the voltage value in this parameter.

- Now you have the proper line voltage value to enter in the control.

Follow the steps below:

- Press E-stop
- **MENU SELECT** key
- **SETUP** key
- Press \wedge (up arrow hard key next to machine hard key)
- **DRIVE SYSTEM** key
- **SUPPLY** key
- **POWER DATA** key See screen below:

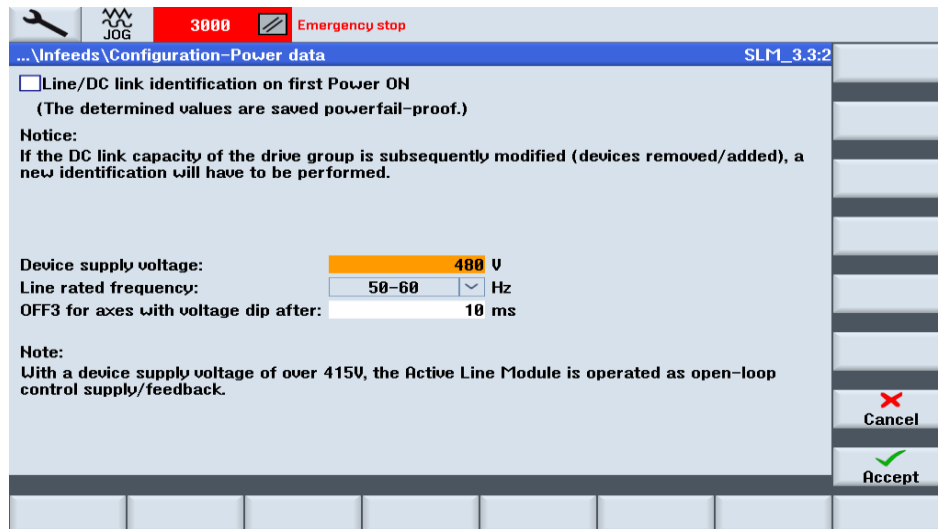

- Scroll down to the **Device Supply Voltage** field like in the screen shot above. Enter the line voltage value you obtained in the previous steps, press enter
- Press **ACCEPT** key
- There will be a message that states, "Confirm You Want to Change the Parameter", Press **YES** key to accept the change.

4.5 M-CODES

An M code in CNC programming controls miscellaneous machine functions, including starting and stopping specific actions or programs.

M00	Program stop
M01	Optional program stop(button on panel must be on
M02	End of Program
M03	Spindle clockwise
M04	Spindle counterclockwise
M05	Spindle stop
M07	Spray mist / air blast
M08	Flood coolant
M09	Coolant off (M07 and M08)
M11	Miscellaneous M-code function on
M12	Miscellaneous M-code function off
M13	Live tool spindle clockwise
M14	Live tool spindle counterclockwise
M15	Live tool spindle off
M17	Reference turret to tool #1
M19	Main spindle orient
M20	Main spindle collet or chuck open (with ID-OD grip switch in OD)
M21	Main spindle collet or chuck close (with ID-OD grip switch in OD)
M22	Tailstock chuck
M23	Tailstock chuck open
M24	Steady rest close
M25	Steady rest open
M26	Tailstock extend (toward Headstock)
M27	Tailstock retract
M29	Rigid Tapping with Live Tools
M30	End of program
M90	Parts catcher catch position
M91	Parts catcher retract stand by position
M33	C axis Brake On
M34	C axis Brake Off
M46	Barfeed cycle-edit barfeed program for alterations
M70	C axis Mode Enable

NOTE: *M-codes may change depending on options the machine is equipped with*

4.6 ALARMS

An alarm will be displayed once a fault occurs.

! *Warning: If you do not heed an alarm that is issued and do not resolve the cause of the alarm, it can present a hazard to the machine, the work piece, the saved settings, and in certain circumstances, may cause injury.*

4.61 Siemens Alarms

1. If a familiar alarm number / description appears carefully check the machine and resolve the cause of the alarm.
2. If you are unfamiliar with the alarm in question, proceed to the alarm list as follows:
 - a. Press **MENU SELECT**
 - b. Select **DIAGNOSTICS**
 - c. Select **ALARM LIST**
3. *Once "**ALARM LIST**" has been selected, press **HELP** key and additional information will be provided on the control screen.

4.62 Fryer PLC Alarms and Descriptions

There are certain PLC alarms in the 700000 range which are not in the **HELP** screen. These are FRYER Machine specific alarms that are for optional equipment installed on the machine. The alarms are listed below:

700000 HEADSTOCK OIL PRESSURE FAULT
700001 LOW WAY LUBE
700002 TURRET THERMAL OVERLOAD
700004 GEARSHIFT FAULT-CHECK AIR PRESSURE
700005 LOW AIR PRESSURE FAULT
700006 LOW HYDRAULIC PRESSURE FAULT
700007 C AXIS HANDWHEEL ACTIVE (X AXIS OFF)
700008 LIVE TOOL DRIVE GEAR NOT ENGAGED!!
700009 CHUCK OR COLLET MUST BE CLOSED TO RUN SPINDLE
700010 HIGH PRESSURE COOLANT ALARM
700012 TURRET NOT INDEXED OR CLAMPED!
700013 TAILSTOCK NOT CLAMPED!
700014 SPINDLE OUT OF GEAR
700015 TAILSTOCK DRAG ARM NOT AT REST POSITION!
700016 WAY OIL PRESSURE SWITCH
700032 CONTOUR HANDWHEEL ACTIVE
700033 DEPRESS HOLD THEN STOP TO STOP SPINDLE DURING AUTO CYCLE
700034 TAILSTOCK NOT CLAMPED
700035 REFERENCE RETURN: PRESS START
700037 DOOR IS OPEN CLOSE DOOR AND PRESS CYCLE START
700038 TOOL SETTER ACTIVE
700039 PART PROBE ACTIVE
700042 TURRET NOT FULLY CLAMPED

4.63 Clearing an Alarm

1. Carefully check the machine according to the description given in the alarm. Clarification of the alarm codes can be found by using the **HELP** as described above.
2. Resolve the cause of the alarm.
3. Press **RESET**
4. Certain alarms will require a reboot of the control to clear.

4.7 WORKING WITH FILES

4.71 File Types

- **NC** archive contains the machine **PARAMETERS**
- **PLC** archive contains the **LADDER LOGIC** for the machine functions
- **DRV** archive contains the **AXIS DRIVE SETTINGS**

4.72 Back-Up An 828 Archive File to A USB Stick

- For a download of the machine archive to a USB , press these three keys at the same time on the control:
CTRL + ALT + S
 - This will create a complete standard Easy Archive (**.ARD**) on a **USB**.
-

If a specific file or additional files need to be backed up to a **USB**, do the following:

PROCEDURE TO BE PERFORMED BY QUALIFIED PERSONNEL ONLY

1. Select the **MENU SELECT**.
2. Select the **STARTUP**.
3. Press the **SYSTEM DATA** key. The data tree will open.
In the data tree, select the required files from which you want to generate an archive.
4. Press the **ARCHIVE** and **GENERATE ARCHIVE** keys.
5. The **GENERATE ARCHIVE: SELECT STORAGE LOCATION** window opens. Select the **USB** location for archiving.
6. Save the file as serial number of machine and the file name (i.e., for drive archive: "25123DRV")
7. Enter a name and press the **OK** key. The directory is created below the selected folder.
8. Press the **OK** key.
9. Select the format archive **ARD** for 828, enter the desired name and press the **OK** key to archive the file/files.
A message informs you if archiving was successful.
10. Press the **OK** key to confirm.
11. An archive file in the **.ARD** (828) format type is created in the selected directory.

*Note: When backing up an entire machine you should generate an individual file for NC, PLC, Drive, and HMI. When that step is completed, you should generate an archive for all these together.

4.73 Reloading an Archive File

PROCEDURE TO BE PERFORMED BY QUALIFIED PERSONNEL ONLY

NOTE: Set the password protection to "Current Access Level: Manufacturer". Refer to Section 4.3 above.

1. Select the **PROGRAM MANAGER** key.
2. Press the **ARCHIVE** and **READ IN ARCHIVE** keys.
3. Select the archive storage location (i.e., **USB**) and position the cursor on the required archive.
4. Note: When the option is not set, the folder for user archives is only displayed if the folder contains at least one archive.

OR

5. Press the **SEARCH** key and in the search dialog, enter the name of the archive file with file extension **.ARD** if you wish to search for a specific archive and press the **OK** key.
6. Press the **OK** or **OVERWRITE ALL** key to overwrite existing files.

OR

7. Press the **DO NOT OVERWRITE** key if you do not want to overwrite already existing files.

OR

8. Press the **SKIP** key if the read-in operation is to be continued with the next file.
9. The **READ IN ARCHIVE** window opens and a progress message box appears for the read-in process.
10. You will then obtain a **READ ERROR LOG FOR ARCHIVE** in which the skipped or overwritten files are listed.
11. Press the **CANCEL** key to cancel the read-in process.

*Note: You may only archive one file at a time.

4.74 Backing Up Tool Data on the 828 Control

Note: Setup data from part programs can only be backed up if they have been saved in the **WORKPIECES** directory.

For part programs, which are located in the **PART PROGRAMS** directory, **SAVE SETUP DATA** is not listed.

1. Select the **PROGRAM MANAGER** operating area.
2. Position the cursor on the program whose tool and zero-point data you wish to back up.
3. Press the **>>** and **ARCHIVE** keys.
4. Press the **SETUP DATA** key.
5. The **BACKUP SETUP DATA** window opens. Select the data you want to back up.
6. Change the specified name of the originally selected program in the **FILE NAME** field, if needed.
7. Press the **OK** key.
8. The setup data will be set up in the same directory in which the selected program is stored as an INI file.

4.8 ADDING A SOFTWARE OPTION ON THE 828 CONTROL

When you receive your machine all license numbers applicable to your order are activated prior to the machine leaving the factory. If you purchase a control option after the machine arrives at your facility you will receive a license number to active on your control. The license will either require you to go online and create a new license key, or this will be already done for you. If you receive a license certificate like pictured in figure one go to step 1, if not and you already have a license (see figure 2) then proceed to step 8 .

1. You need to obtain the hardware serial # (this not the same as the control serial number) follow these steps:

- Press **MENU SELECT**
- Press **SETUP**
- Select **LICENSE** (you may have to press the ^ or > key to see the soft key)
- Record the **CF CARD SERIAL #**

This number can also be found in the CF card located in your electrical cabinet. The number on the card is labeled as CFC SN. **CAUTION:** Machine must be powered down before the card is removed.

2. Once you have obtained your Control Hardware Serial Number you are ready to activate your new license number. Using the internet, log onto: www.Siemens.com/Automation/License
- Click on the link for **DIRECT ACCESS**
 - Enter the **LICENSE # AND DISPATCH NOTE #** from the paperwork into the areas indicated on the web page.

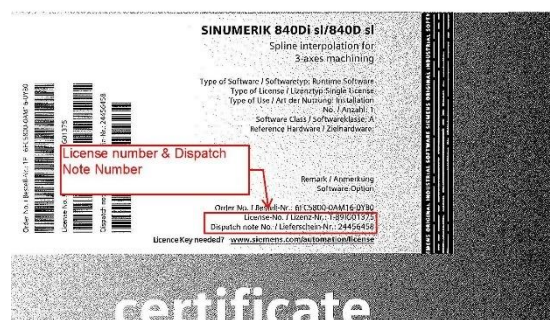

3. Click **NEXT**
4. On the next screen enter your hardware serial number.
5. Next select the control model. Your machine has a 828.
6. The system will now return a software license key
7. Download PDF and save for your records. Also print the PDF so you can refer to it at the machine to type in new license key.
8. Already have printed license see below:



9. Follow step 1 to get to the license screen. Type in (overwriting old license key) current license key and press input. The field is highlighted, make sure to enter correctly.

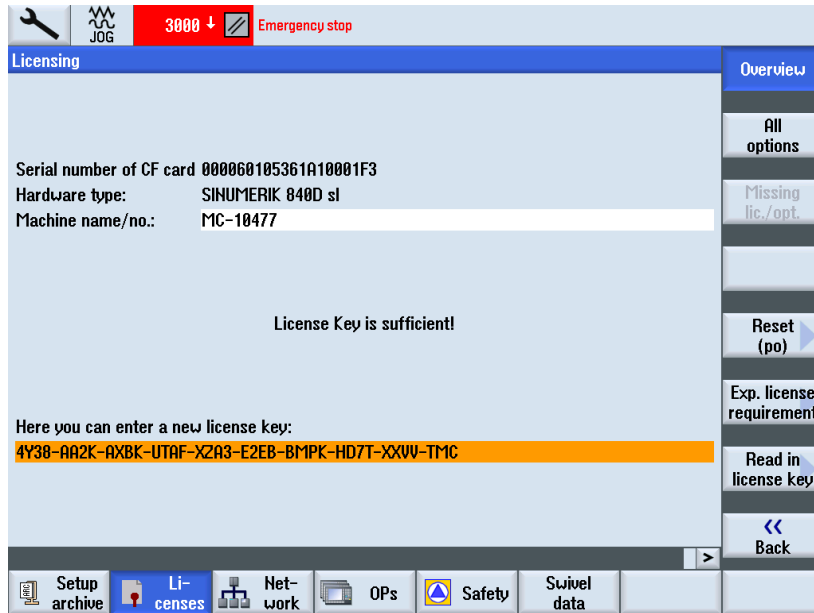

Figure 3

10. Press all options soft key
11. Search for the particular option you want to activate. Set the box with the select key. See figure 4.

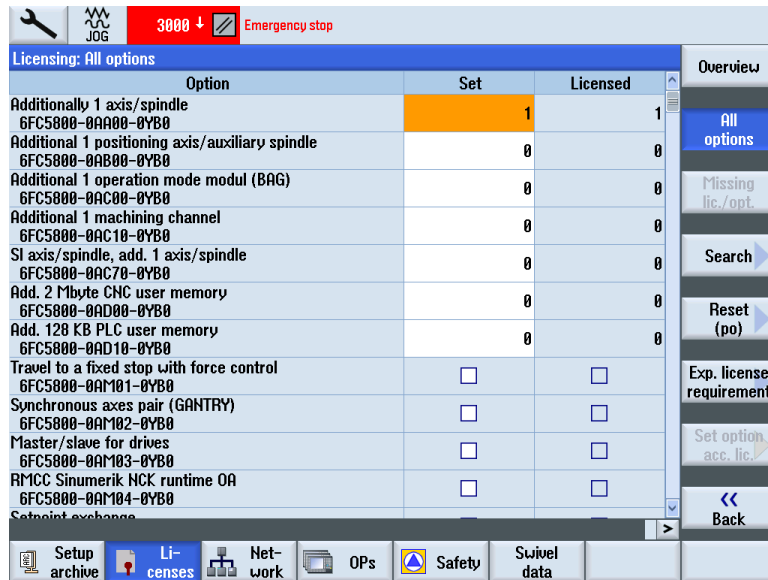

Figure 4

12. Press back soft key and power machine down. When you turn the machine back on the option should be activated.

4.9 SET UP THE NETWORK DRIVE IN AN 828

! NOTE: *It is recommended that this procedure be performed by an experienced network administrator.*

The transfer of programs can be achieved by mapping a soft- key to a networked computer. The soft key will appear in the Program Manager screen of the controller.

The computer connected to the network must be configured with a unique username and password. This information will be required for inputting on the controller. A dedicated shared folder is required on the PC for the storage of files.

- Refer to Section 4.1 for directions to access parameter screens.
1. Press **MENU SELECT**
 2. Select **SETUP**
 3. Select **START-UP**

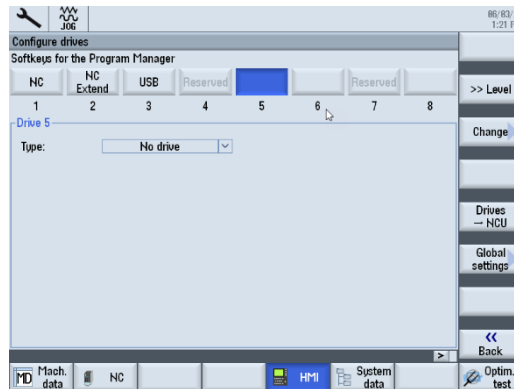

4. Press the **HMI** and **LOG. DRIVE** keys. The **SET UP DRIVES** window opens.
5. Select the open key that you want to configure (**example #5**).
6. To allow entry fields to be edited, press the **CHANGE** key.
7. Select the data for the corresponding drive or enter the necessary data.

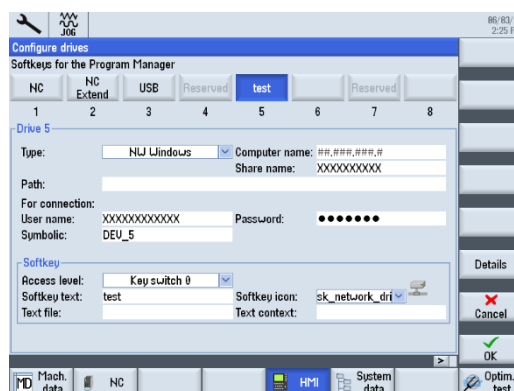
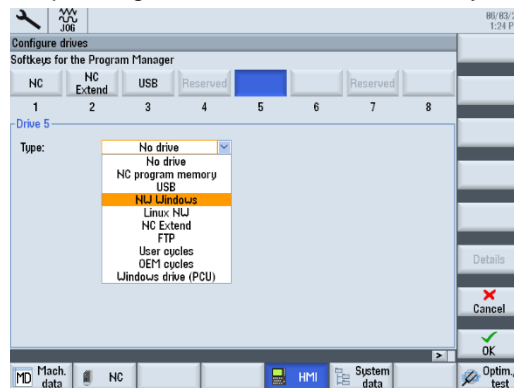

8. Press the **OK** key. The entries are checked. A window with the appropriate message opens if the data is incomplete or incorrect. Acknowledge the message with **OK** key. If you press the **CANCEL** key, then all of the data that has not been activated is rejected.
9. Restart the control in order to activate the configuration and to obtain the keys in the **PROGRAM MANAGER** screen.



5.0 TURRET

5.1 REMOVAL AND ALIGNING THE TURRET

1. Remove Sheet metal covers. Light has a plug inside the panel.
2. Turn the Machine OFF. LOTO. Remove both sets of orange (motor power) and green (encoder) cables.

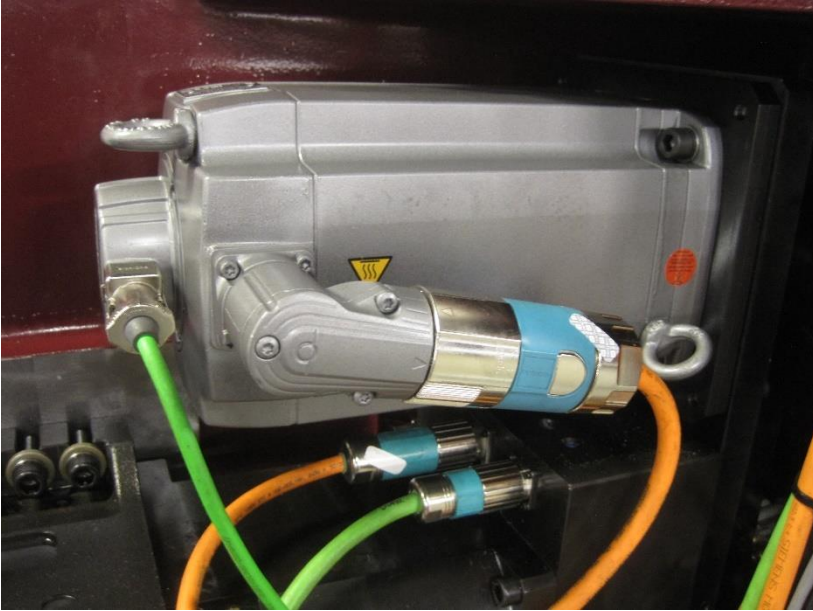

3. Remove 2 hydraulic (Jic 6) hoses, and cap them off. Also cap off the turret. Make sure to mark the hoses for proper installation.

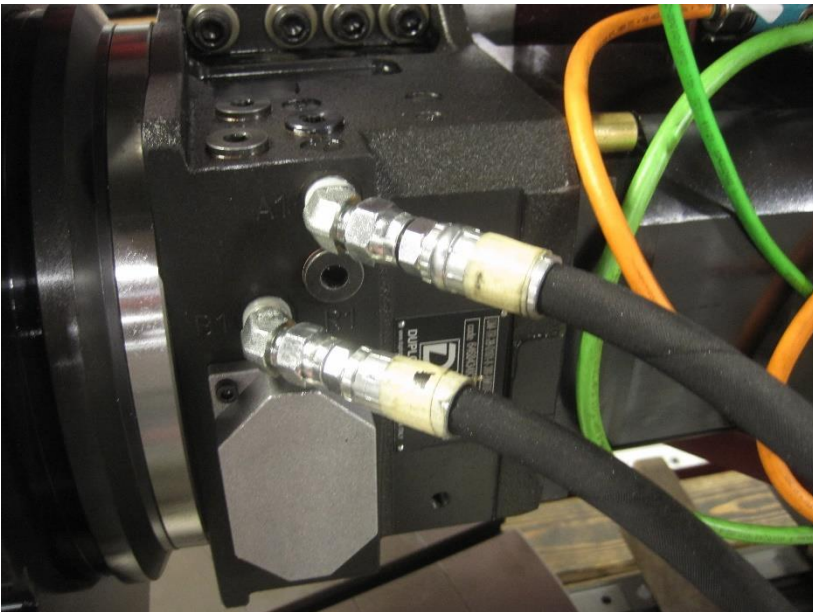

4. Remove Coolant hose (Jic 6) and cap off.

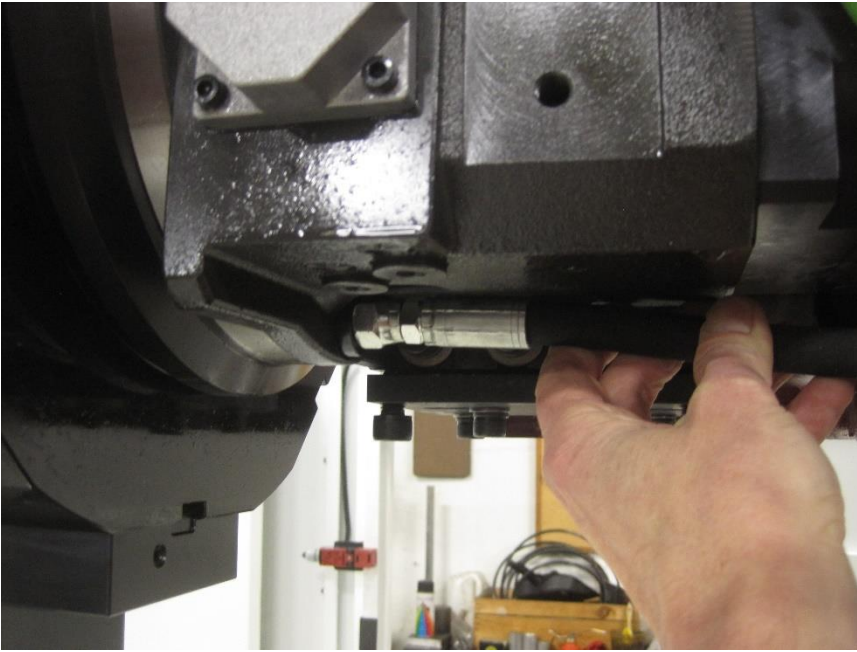

5. Install Eyehook, and chock strap around the faceplate neck, to support the turret with overhead crane, or forklift. Loosen the 8 turret mounting bolts, and remove.

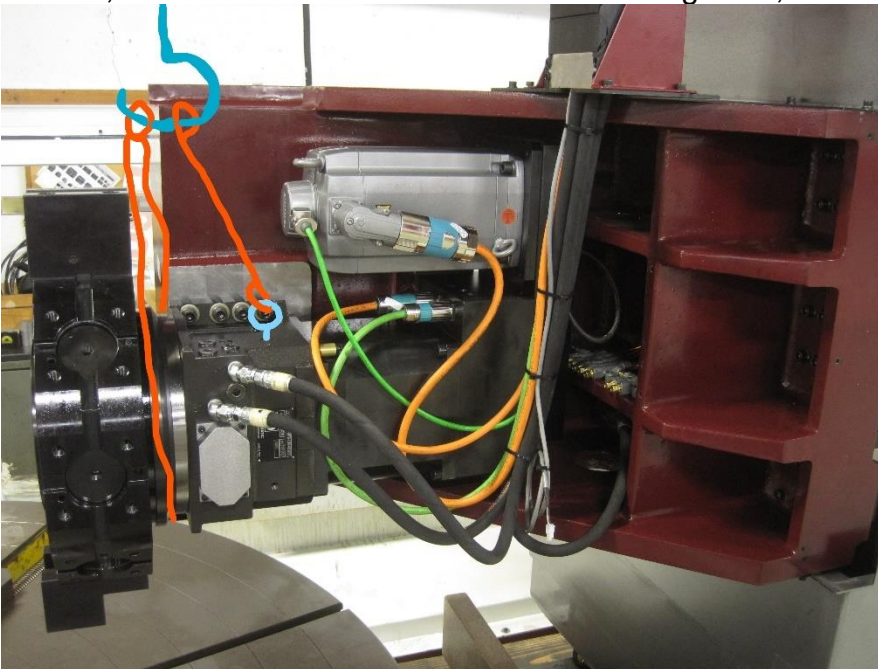

6. Package the turret in a Wood crate.
7. To reinstall, reverse above procedure.
8. Once all cables and hoses are attached, you must bleed all the air out of the hydraulic lines. You can crack open the ports on the top of the turret, while manually actuating the hydraulic turret clamp solenoid. Do it slowly, and watch the oil level in the tank, so not to introduce more air into the unit. If the turret gets a time out fault, it is always because there is still air in the hydraulic lines.
9. Realign the turret to be parallel and center with the machine travel.

5.2 DUPLOMATIC ERROR ALARM CODES



DUPLOMATIC

E.M.TMC-230V RELEASE7 10-10

5. DIAGNOSTIC

ALARMS AND WARNINGS

The electronic unit constantly executes self-diagnosis and can signal alarms condition.

An alarm is present if READY is LOW and an ALPOSXX output is different from zero

Turret is in normal operation if READY= ON: in this case the ALPOSxx outputs give the code of the current position.

When an alarm occurs the READY = OFF: in this case ALPOSxx outputs give the alarm code in binary format (ALPOS01= LSB).

Starting from FW 2.0 there is no more separation in group and subgroup.

OUTPUTS						Actual position (READY= ON)	ALARM CODE (READY= OFF)	ALARM DESCRIPTION (READY= OFF)
ALPOS32	ALPOS16	ALPOS08	ALPOS04	ALPOS02	ALPOS01			
0	0	0	0	0	0	Out of position	0.0	No alarm
0	0	0	0	0	1	1	0.1	Non consistent parameters in memory.
0	0	0	0	1	0	2	0.2	Failure in internal power supply.
0	0	0	0	1	1	3	0.3	External 24V DC supply is too low.
0	0	0	1	0	0	4	0.4	Thermal I ² t threshold reached.
0	0	0	1	0	1	5	0.5	Motor overspeed.
0	0	0	1	1	0	6	0.6	Overload: check inertia and friction, check motor and resolver wirings.
0	0	0	1	1	1	7	0.7	Short circuit on power stage: check servomotor wiring or internal damage. (1)
0	0	1	0	0	0	8	0.8	Ground leakage in power stage, check wirings to motor and servomotor. (1)
0	0	1	0	0	1	9	0.9	Internal braking resistor circuit error. (1)
0	0	1	0	1	0	10	1.0	Trouble on power stage control section. (1)
0	0	1	0	1	1	11	1.1	Overvoltage during motor braking. Reduce inertia on the disk. (1)
0	0	1	1	0	0	12	1.2	Undervoltage on threephase
0	0	1	1	0	1	13	1.3	Short circuit on resolver power line (RPOW+, RPOW-) or broken wire on (RSIN+, RSIN-, RCOS+, RCOS-).
0	0	1	1	1	0	14	1.4	Fault on digital outputs: check for external shorts or overloads.
0	0	1	1	1	1	15	1.5	Profile generator fault.
0	1	0	0	0	0	16	1.6	HW ENABLE is not present.
0	1	0	0	0	1	17	1.7	Positioning timeout
0	1	0	0	1	0	18	1.8	Heatsink overtemperature. (1)
0	1	0	0	1	1	19	1.9	Overvoltage on threephase line. Check main supply. (1)
0	1	0	1	0	0	20	2.0	Reached maximum positioning error.
0	1	0	1	0	1	21	2.1	Timeout in cycle execution.
0	1	0	1	1	0	22	2.2	Motor overtemperature. (1)
0	1	0	1	1	1	23	2.3	The signal of Locking switch does not go OFF during unclamping.
0	1	1	0	0	0	24	2.4	The signal of Locking switch has gone ON while turret is unclamped.
0	1	1	0	0	1	N.A.	2.5	The unclamping phase is too slow, check the pressure, and purge the hydraulic circuit.
0	1	1	0	1	0	N.A.	2.6	N.A.
0	1	1	0	1	1	N.A.	2.7	N.A.
0	1	1	1	0	0	N.A.	2.8	The signal of Locking switch has gone OFF while turret is clamped.
0	1	1	1	0	1	N.A.	2.9	Clamping timeout.
0	1	1	1	1	0	N.A.	3.0	N.A.
0	1	1	1	1	1	N.A.	3.1	Need to run the the setup procedure.
1	0	0	0	0	0	N.A.	3.2	Requested tool is not existing
1	0	0	0	0	1	N.A.	3.3	Parity error on tool number request.
1	0	0	0	1	0	N.A.	3.4	PBITXX are changed but PSTART did not came on time.
1	0	0	0	1	1	N.A.	3.5	PLC set EMERGENCY MODE during turret cycle
1	0	0	1	0	0	N.A.	3.6	Trouble during setup procedure execution
1	0	0	1	0	1	N.A.	3.7	Cannot clamp during setup procedure.
1	0	0	1	1	0	N.A.	3.8	Error in D current controller. Check motor and resolver wirings.
1	0	0	1	1	1	N.A.	3.9	Error in Q current controller. Check motor and resolver wirings.
1	0	1	0	0	0	N.A.	4.0	Error in speed controller.
1	0	1	0	0	1	N.A.	4.1	Error in position controller.



1	0	1	0	1	0	N.A.	4.2	N.A.
1	0	1	0	1	1	N.A.	4.3	N.A.
1	0	1	1	0	0	N.A.	4.4	N.A.
1	0	1	1	0	1	N.A.	4.5	N.A.
1	0	1	1	1	0	N.A.	4.6	N.A.
1	0	1	1	1	1	N.A.	4.7	N.A.
1	1	0	0	0	0	N.A.	4.8	N.A.
1	1	0	0	0	1	N.A.	4.9	N.A.
1	1	0	0	1	0	N.A.	5.0	N.A.
1	1	0	0	1	1	N.A.	5.1	N.A.
1	1	0	1	0	0	N.A.	5.2	N.A.
1	1	0	1	0	1	N.A.	5.3	N.A.
1	1	0	1	1	0	N.A.	5.4	N.A.
1	1	0	1	1	1	N.A.	5.5	N.A.
1	1	1	0	0	0	N.A.	5.6	N.A.
1	1	1	0	0	1	N.A.	5.7	N.A.
1	1	1	0	1	0	N.A.	5.8	N.A.
1	1	1	0	1	1	N.A.	5.9	N.A.
1	1	1	1	0	0	N.A.	6.0	N.A.
1	1	1	1	0	1	N.A.	6.1	N.A.
1	1	1	1	1	0	N.A.	6.2	N.A.
1	1	1	1	1	1	N.A.	6.3	N.A.

N/A = No alarm and/or position associated to this code.

(1) = strongly suggested to switch off the threephase supply to TMC controller when power driver alarms are detected.

Display:

A 7-segment display is available.

When the driver is in normal condition all the segments are blinking in sequence.

When the alarm is present, the display will show in sequence, A->(first alarm digit)-> (second alarm digit)

As example, the alarm 2.3 is

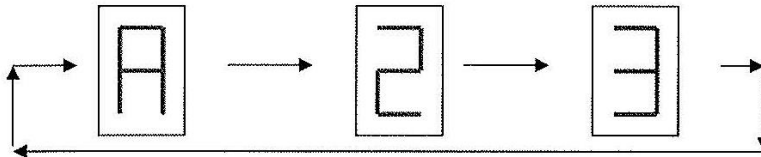

Alarm are stored and can be reset with EMERGENCY/RESET function.

Power off causes the reset of the active alarm.

A PC software is available to improve the stat-up procedure and troubleshooting.

Fault of electronic unit:

After recognizing the fault, the problem can be easily solved.

In case of electronic unit fault, it can be easily replaced.

6.0 DRAWINGS AND PARTS LIST PARTS

6.1 828 CONTROL ELECTRICAL PANEL LAYOUT

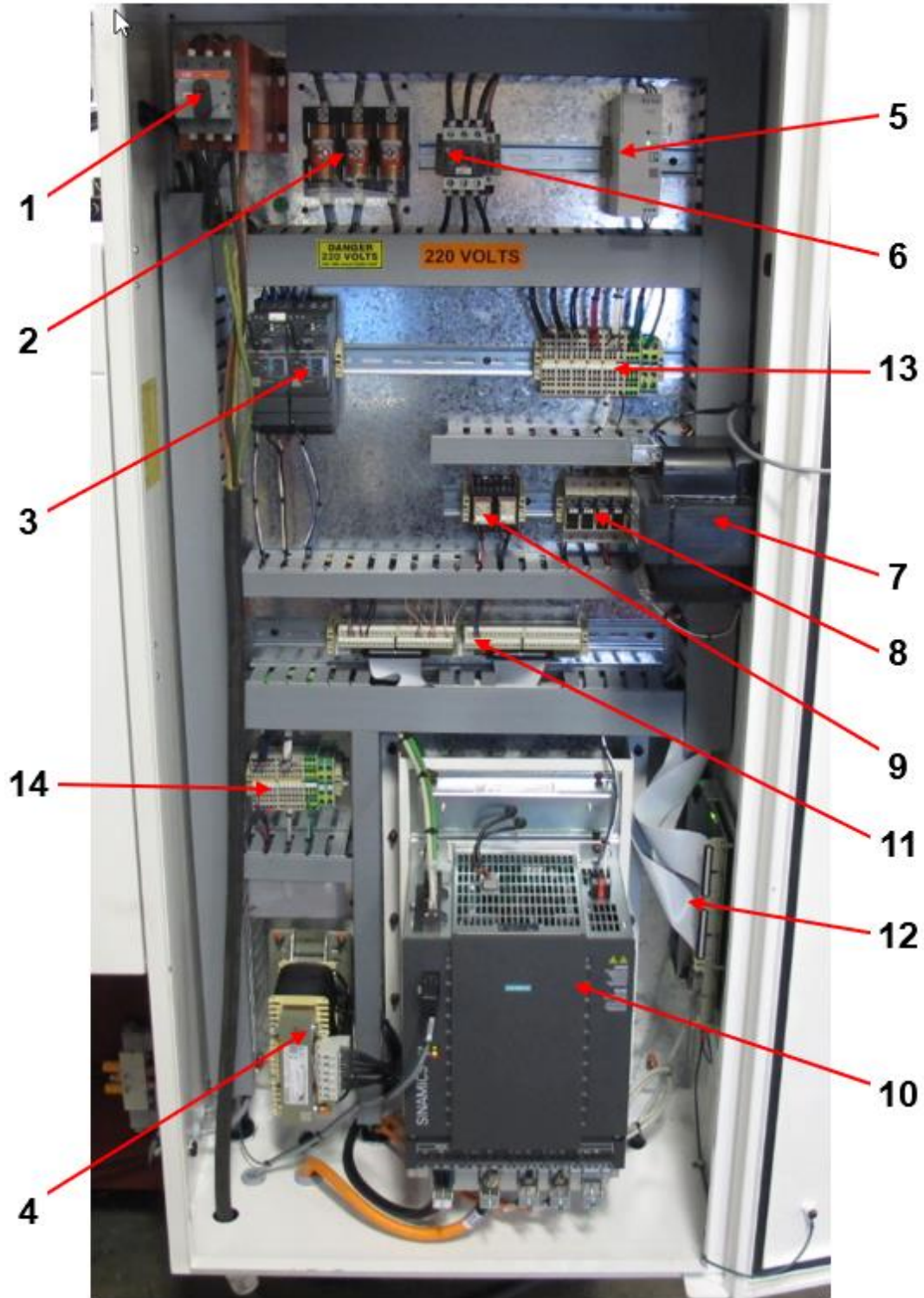

6.1 828 CONTROL ELECTRICAL PANEL – PARTS

REF	PART NO.	DESCRIPTION	PARTS NAME	QTY
1	SWT-5064	Main disconnect		1
2	MSE-1912	Fuse block		1
3		Motor controller overloads		1
4		Line choke		1
5	MSE-2940	24 VDC power supply		1
6	MSE-1410	MC1 magnetic contactor		1
7	MSE-1610	Transformer		1
8		Fuse panel		1
9		Contact relays		1
10		Combi drive		1
11		I/O breakout board		1
12	MSE-1330	I/O card		1
13		Terminal block		1
14		Terminal block		1

6.2 828 FRONT CONSOLE LAYOUT & PARTS



REF	PART NO.	DESCRIPTION	PARTS NAME	QTY
1	MON-4378	Siemens Monitor NCU		1
2	CMB-3202	Siemens Control Panel		1
3	DCL-6052	Apron Panel Decal		1
4	HDL-6094	Handwheel for ET-18/21/25 X & Z		2
5	MSM-8210	Keys (3)		1 set
6	SWT-5052	Joystick Switch		1
7	70131528	Fine / Coarse Toggle Switch		1
8	SwT-6210	e-Stop w/ Contact Block		1

6.3 BASE CASTING ASSEMBLY DRAWING & PARTS LIST

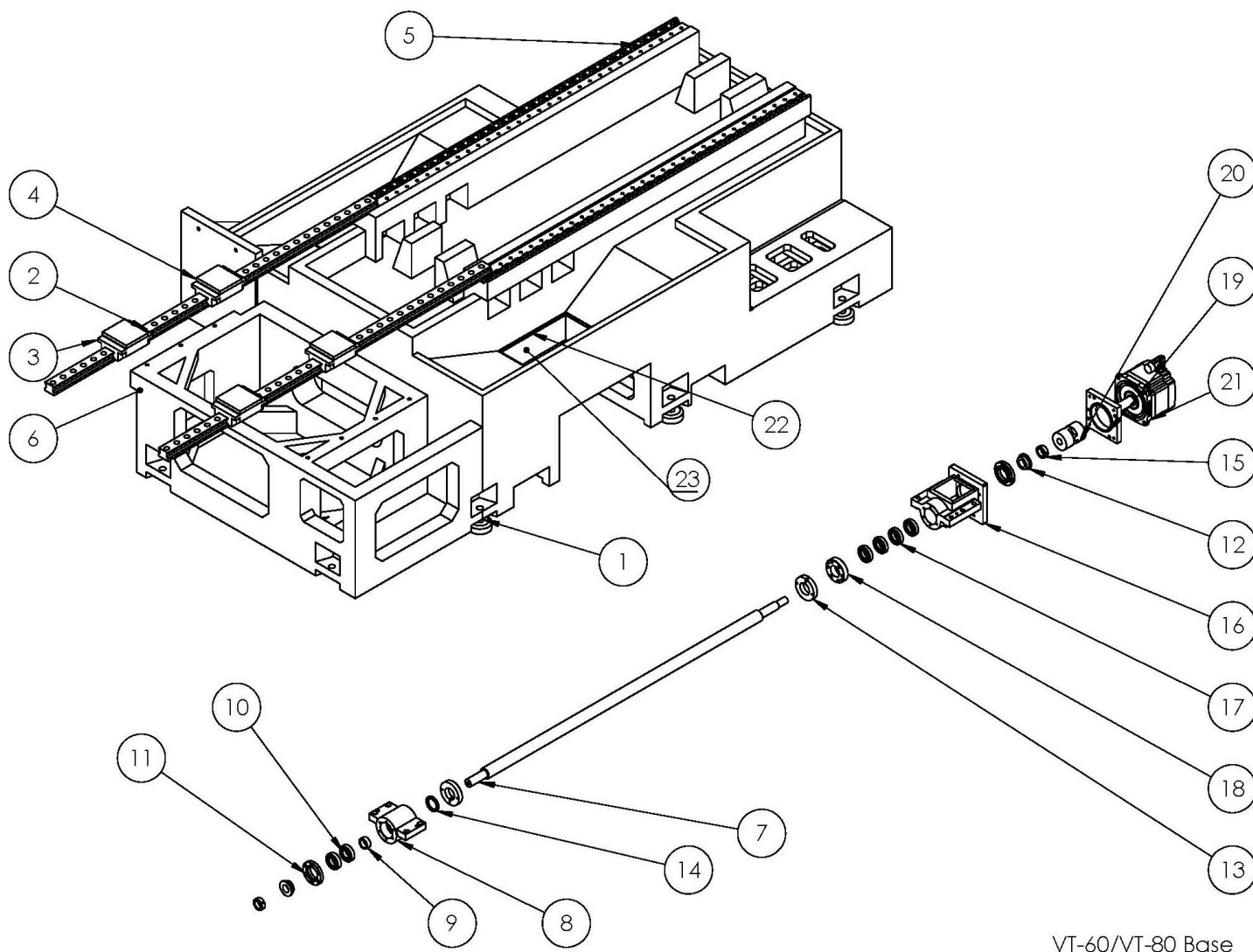

VT-60/VT-80 Base

VT-60/VT-80 Base part list					
Item No.	Part Name	Part number	Q'ty	Jointly part VT-60/80	Do not joint part VT-60/80
1	VT-60 Foot pad	VT60B001	8	V	
2	X Linear Rail HIWIN RGW55CC2R1920ZBPII(VT-60)	VT60B002	2		V
3	X Linear Bearing Packs HIWIN RGW55CC2R1920ZBPII(VT-60)	VT60B003	4	V	
4	VT-60 Shim 4	VT60B004	4	V	
5	T3	VT60B005	64	V	

6	VT-60 Base	VT60B006	1		V
7	X Ball Screw HIWIN R50-10T5-FDDC- 1492-1876-0.008(VT-60)	VT60B007	1		V
8	VT-60 X, Z Fixed Bracket	VT60B008	1	V	
9	VT-60 Collar 4	VT60B009	1	V	
10	Bearing 6207ZZ	VT60B010	2	V	
11	VT-60 bracket cover	VT60B011	2	V	
12	VT-60 Collar 1	VT60B012	2	V	
13	VT-60 Collar 3	VT60B013	2	V	
14	Oil seal 50X68X8	VT60B014	1	V	
15	lock nut YSF M35X1.5	VT60B015	2	V	
16	VT-60 X.Z Ballscrew bracket	VT60B016	1	V	
17	Bearing 35TAC 72B	VT60B017	4	V	
18	VT-60 Collar 2	VT60B018	1	V	
19	VT-60 X.Z motor bracket	VT60B019	1	V	
20	Coupling 80X 28X38	VT60B020	1	V	
21	1FK7101-2AF71-1RG0	VT60B021	1	V	
22	Metal Strips	VT60B022	2 sets		V
23	Rubber Flaps	VT60B023	2 sets		V

6.4 SADDLE DRAWING & PARTS LIST

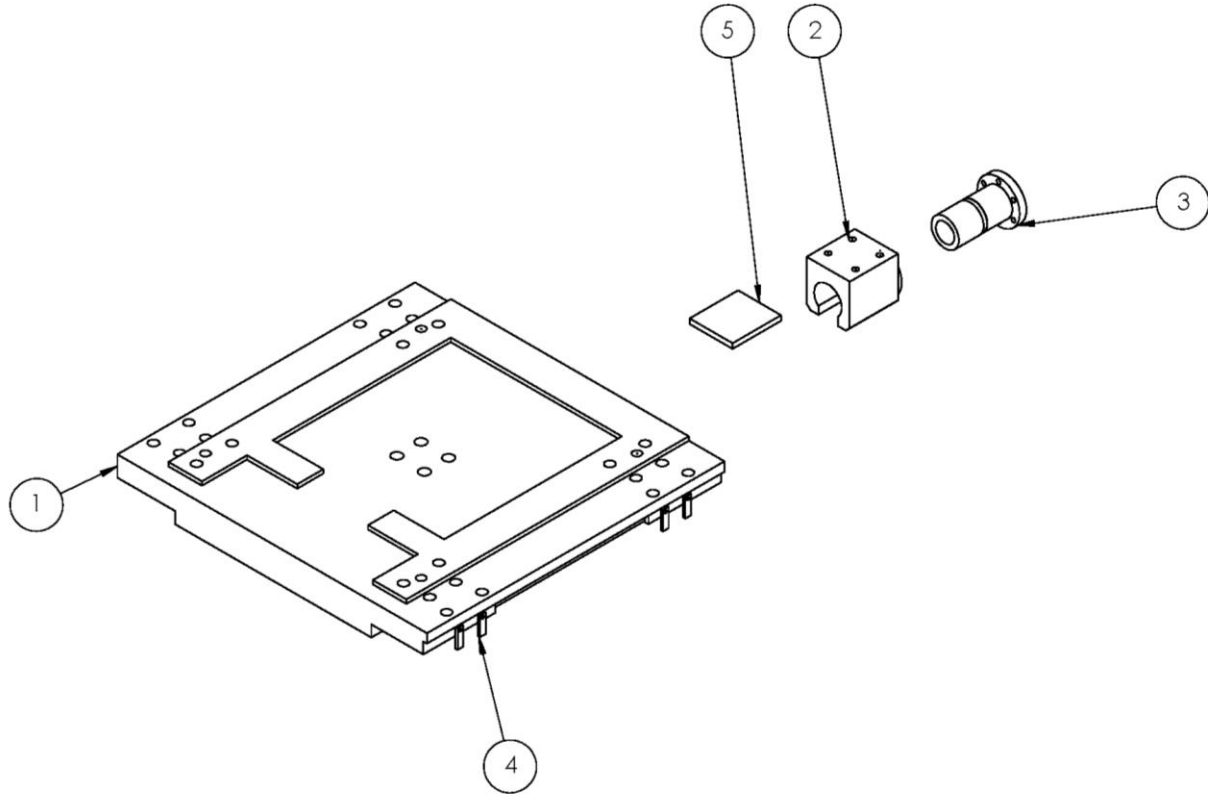

VT-60/VT-80 Saddle

VT-60/VT-80 Saddle part list					
Item No.	Part Name	Part Number	Q'ty	Jointly part VT-60/80	Do not joint part VT- 60/80
1	VT-60 Saddle	VT-60S001	1	V	
2	VT-60 X Flage Bracket	VT-60S002	1	V	
3	X Ballscrew Flage HIWIN R50-10T5- FDDC-1492-1876-0.008(VT-60)	VT-60S003	1	V	
4	VT-60 Fasten plate 1	VT-60S004	4	V	
5	VT-60 shim 2	VT-60S005	1	V	

6.5 COLUMN DRAWING & PARTS LIST

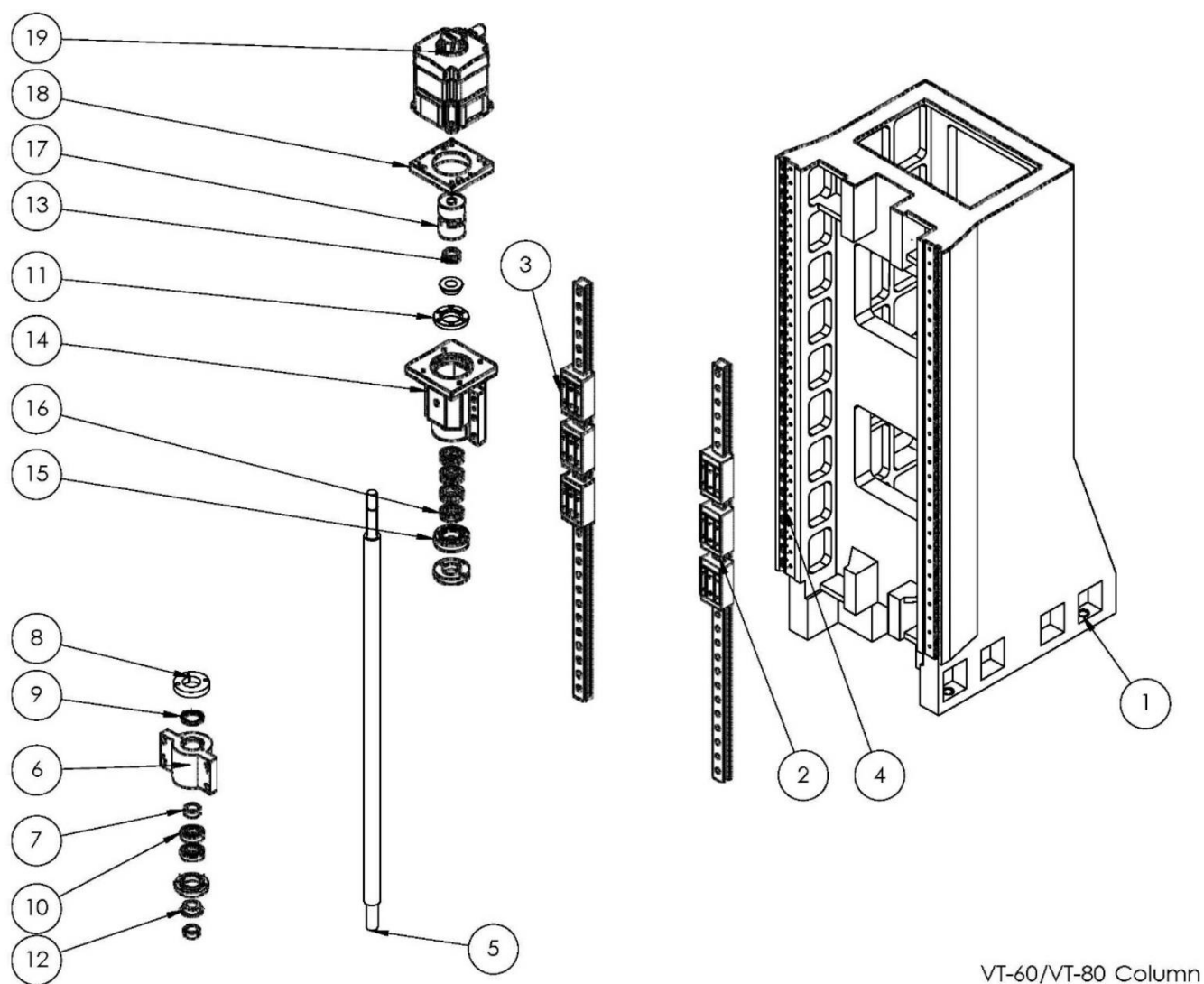

VT-60/VT-80 Column

VT-60/VT-80 Column Part list

Item No.	Part Name	Part Number	Q'ty	Jointly part VT-60/80	Do not joint part VT-60/80
1	VT-60 Column	VT60C001	1	V	
2	Z Linear Rail HIWIN RGH45CA3R1970ZBPII(VT-60 Z 48.1" Travel)	VT60C002	2		V
3	Z Linear Bearing Packs HIWIN RGH45CA3R1970ZBPII(VT-60 Z 48.1" Travel)	VT60C003	6	V	
4	T2	VT60C004	58	V	
5	Z Ballscrew HIWIN R50-10K5-FDC-1735-2108-0.008(VT-60 Z 48.1" Travel)	VT60C005	1		V
6	VT-60 X, Z Fixed Bracket	VT60C006	1	V	
7	VT-60 Collar 4	VT60C007	1	V	

8	VT-60 Collar 3	VT60C008	2	V	
9	Oil seal 50X68X8	VT60C009	1	V	
10	Bearing 6207ZZ	VT60C010	2	V	
11	VT-60 bracket cover	VT60C011	2	V	
12	VT-60 Collar 1	VT60C012	2	V	
13	lock nut YSF M35X1.5	VT60C013	2	V	
14	VT-60 X.Z Ballscrew bracket	VT60C014	1	V	
15	VT-60 Collar 2	VT60C015	1	V	
16	Bearing 35TAC 72B	VT60C016	4	V	
17	Coupling 80X 28X38	VT60C017	1	V	
18	VT-60 X.Z motor bracket	VT60C018	1	V	
19	1FK7101-2AF71-1RH0	VT60C019	1	V	

6.6 RAM DRAWING & PARTS LIST

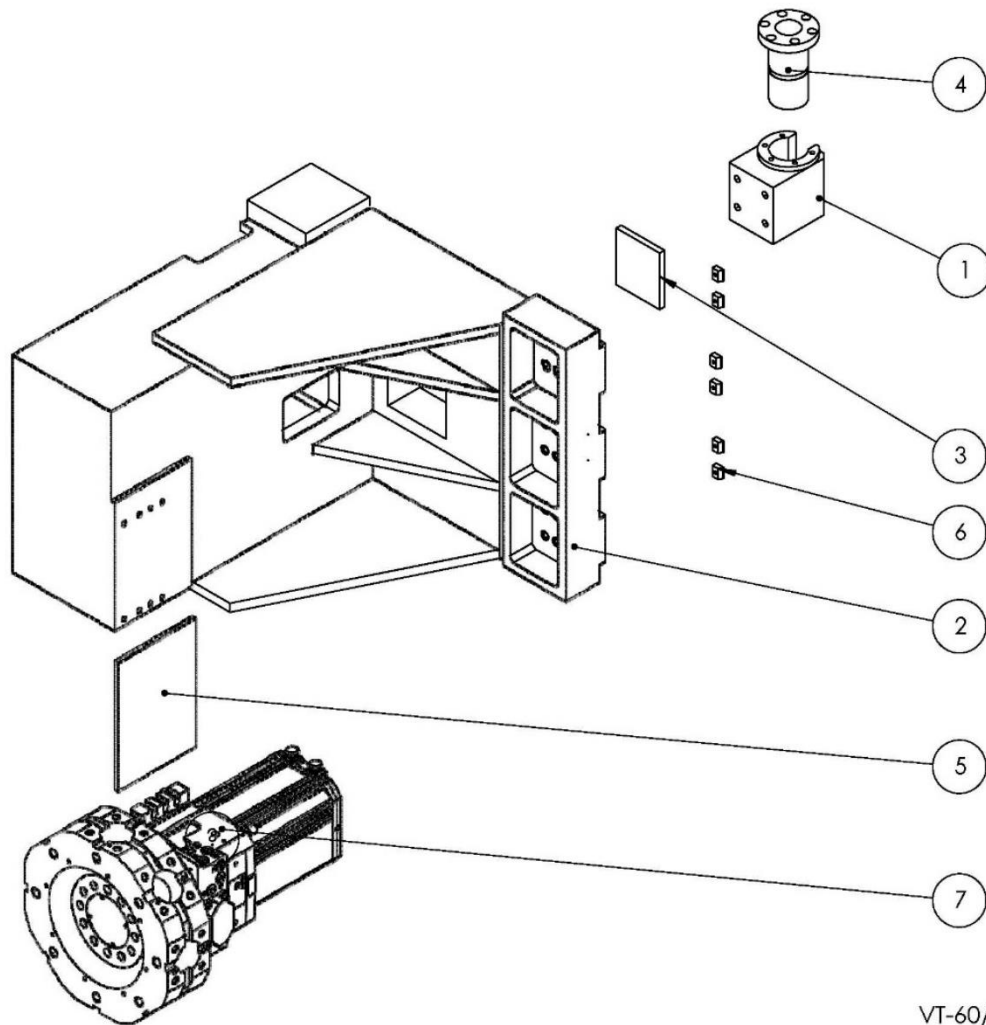

VT-60/VT-80 Ram Part list

Item No.	Part Name	Part Number	Q'ty	Jointly part VT-60/80	Do not joint part VT-60/80
1	VT-60 Z Flange Bracket	VT60R001	1	V	
2	VT-60 Ram	VT60R002	1		V
3	VT-60 shim 2	VT60R003	1		V
4	Z Ballscrew Flange HIWIN R50-10K5-FDC- 1735-2108-0.008(VT-60 Z 48.1" Travel)	VT60R004	1	V	
5	VT-60 Shim 5	VT60R005	1		V
6	T2	VT60R006	6	V	
7	Turret	VT60R007	1		V

6.7 HEADSTOCK DRAWING & PARTS LIST

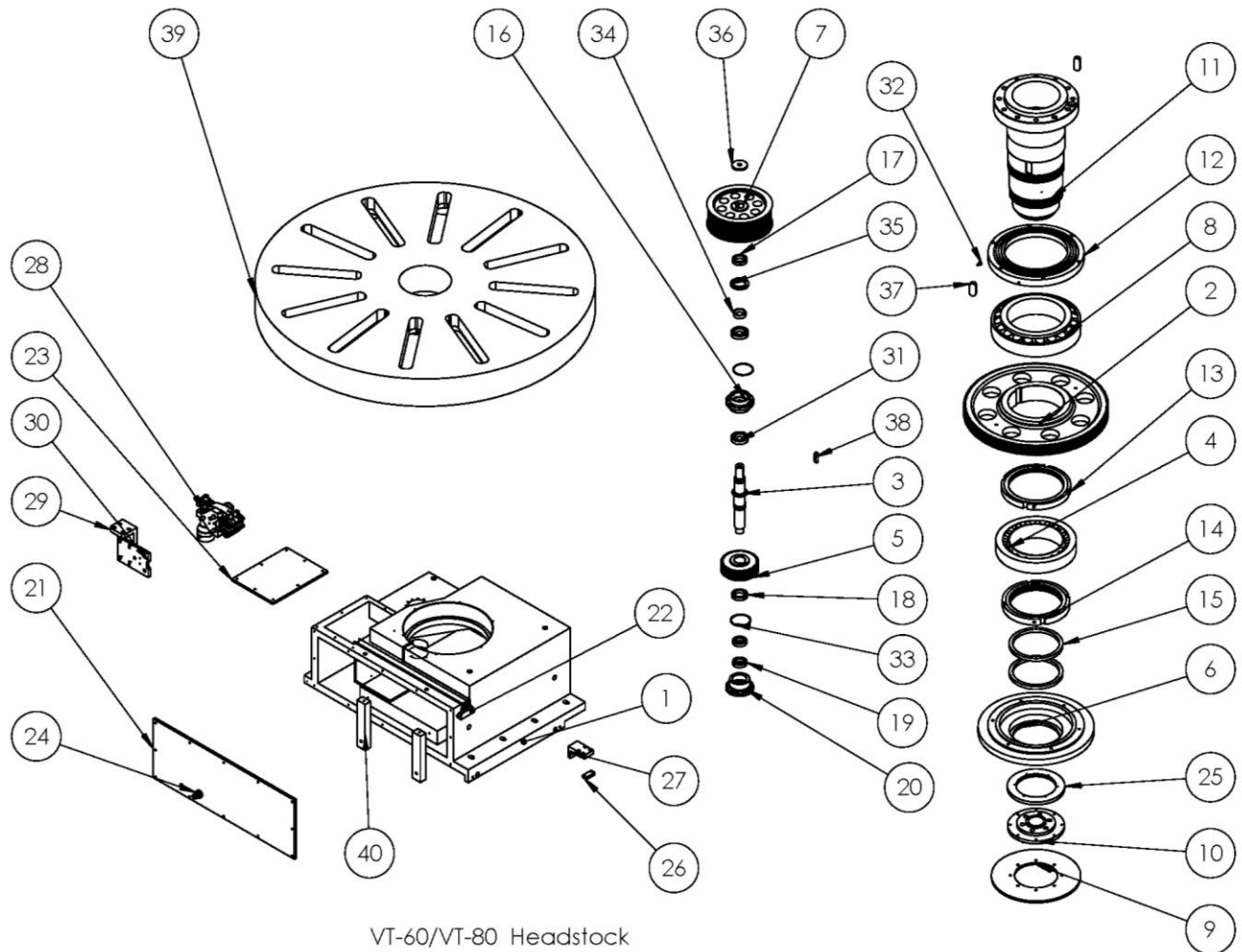

VT-60/VT-80 Headstock

VT-60/VT-80 Headstock Part List

Item No.	Part Name	Part Number	Q'ty	Jointly part VT-60/80	Do not joint part VT- 60/80
1	VT-60 Headstock	VT60H001	1	V	
2	VT-60 Spindle gear 160T-M4	VT60H002	1	V	
3	VT-60 A Shaft	VT60H003	1	V	
4	Bearing 32048X	VT60H004	1	V	
5	VT-60 Gear 40T -M4	VT60H005	1	V	
6	VT-60 spindle cover	VT60H006	1	V	
7	Pulley HTD-8M-112T	VT60H007	1	V	
8	Bearing 32052X	VT60H008	1	V	
9	VT-60 Disc Brake Rotor	VT60H009	1	V	
10	SIN -S 150 Adapter	VT60H010	1	V	

11	VT-60 Spindle A1-15	VT60H011	1	V	
12	VT-60 Head front cover	VT60H012	1	V	
13	Lock nut M250P2.0	VT60H013	1	V	
14	Lock nut M240P2.0	VT60H014	1	V	
15	Oil seal TC 210X240X15	VT60H015	2	V	
16	VT-60 A Shaft cover 1	VT60H016	1	V	
17	lock nut YSR M45X1.5	VT60H017	1	V	
18	lock nut YSR 50X1.5	VT60H018	1	V	
19	Bearing 6007ZZ	VT60H019	2	V	
20	VT-60 A Shaft cover 2	VT60H020	1	V	
21	VT 60 Headstock plate I	VT60H021	1	V	
22	AB-4-8-6 Distributor	VT60H022	1	V	
23	VT-60 Headstock plate 2	VT60H023	1	V	
24	PIP32320	VT60H024	1	V	
25	Encoder ERM200-- I80	VT60H025	1	V	
26	VT-60 Spindle Encoder mount	VT60H026	1	V	
27	VT-60 Spindle Encoder mount upper	VT60H027	1	V	
28	A2686	VT60H028	1	V	
29	VT-60 Brake bracket upper	VT60H029	1	V	
30	VT-60 Brake bracket	VT60H030	1	V	
31	Bearing 7009	VT60H031	2	V	
32	PD-601set	VT60H032	1	V	
33	O-Ring G85	VT60H033	2	V	
34	VT-60 Ring	VT60H034	1	V	
35	Oil seal 55X80X8	VT60H035	1	V	
36	VT-60 Step washer	VT60H036	1	V	
37	VT-60 Spindle Key	VT60H037	2	V	
38	VT-60 Shaft Key	VT60H038	1	V	
39	VT-60 Face plate 60 in	VT60H039	1		v
40	VT-60 Headstock Support	VT60H040	2	V	

6.8 OIL TANK DRAWING & PARTS LIST

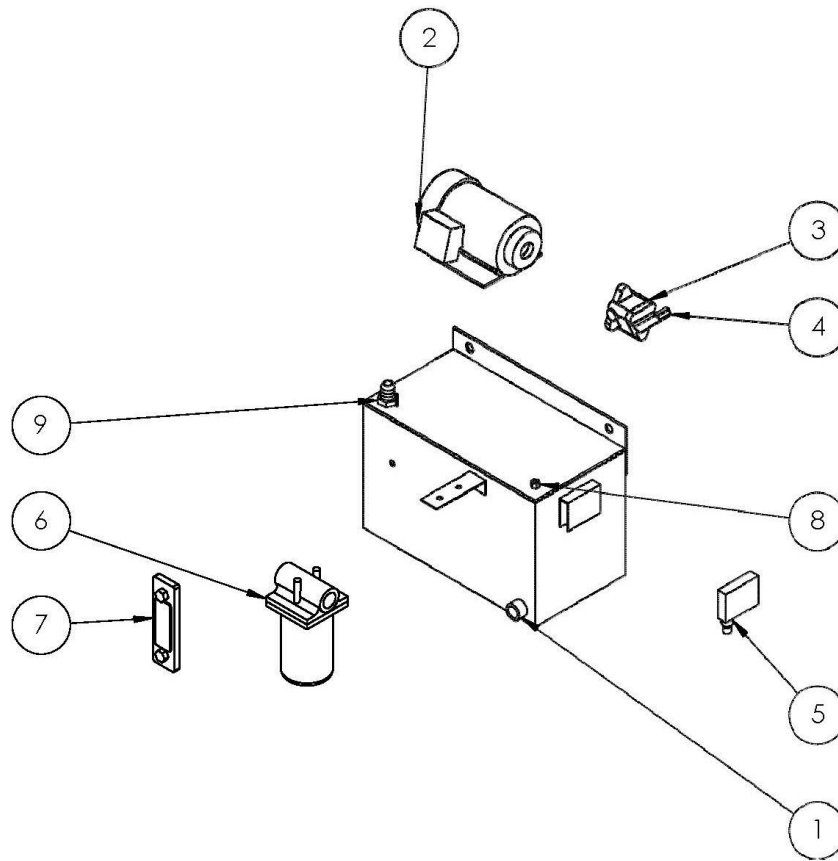

VT-60/VT-80 Oil Tank

VT-60/VT-80 Oil Tank Part List

Item No.	Part Name	Part Number	Q'ty	Jointly part VT-60/80	Do not joint part VT-60/80
1	VT-60 Oil tank	VT60P001	1	V	
2	PMO-0-02-E-3-1 Oil motor	VT60P002	1	V	
3	CYP-12A Oil pump	VT60P003	1	V	
4	CYP-AV Valve for Oil pump	VT60P004	1	V	
5	M21041 Pressure switch	VT60P005	1	V	
6	PFPAM10E0 Oil Cleaner	VT60P006	1	V	
7	Oil Window	VT60P007	1	V	
8	Pipe Adapter	VT60P008	1	V	
9	PIP32320	VT60P009	1	V	

6.9 SPINDLE MOTOR DRAWING & PARTS LIST

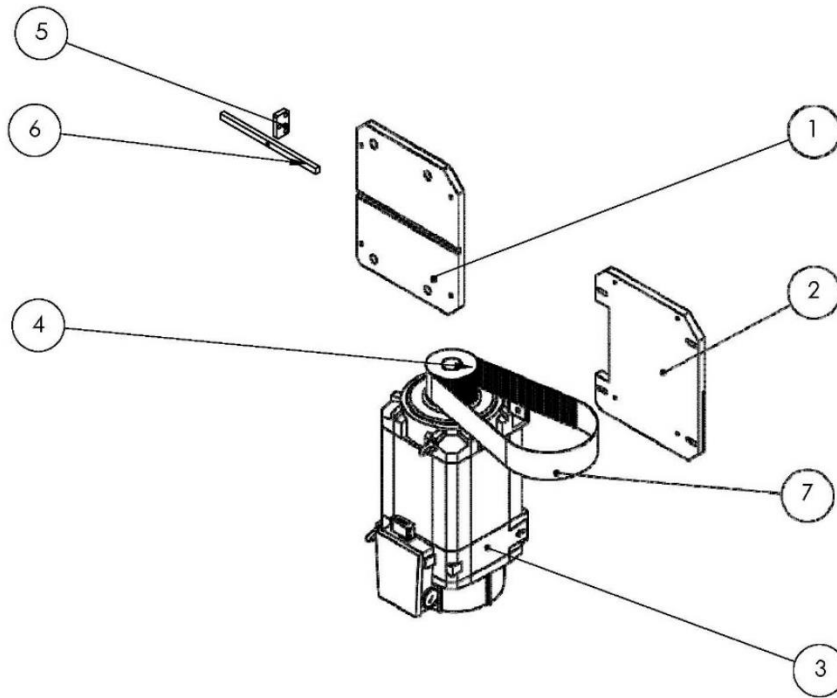

VT-60/VT-80 Spindle motor

VT-60/VT-80 Spindle motor part list

Item No.	Part Name	Part Number		Jointly part VT-60/80	Do not joint part VT-
1	VT-60 Motor plate 1	VT60M001	1	V	
2	VT-60 Motor plate 2	VT60M002	1	V	
3	1PH8165-1DD00-1DA1	VT60M003	1	V	
4	Pulley HTD-8M-56T	VT60M004	1	V	
5	VT-60 Motor adjuster	VT60M005	1	V	
6	VT-60 Key -motor plate	VT60M006	1	V	
7	Belt 1480-8M-3.75"	VT60M007	1	V	

6.10 SCALE MOUNT DRAWING & PARTS LIST

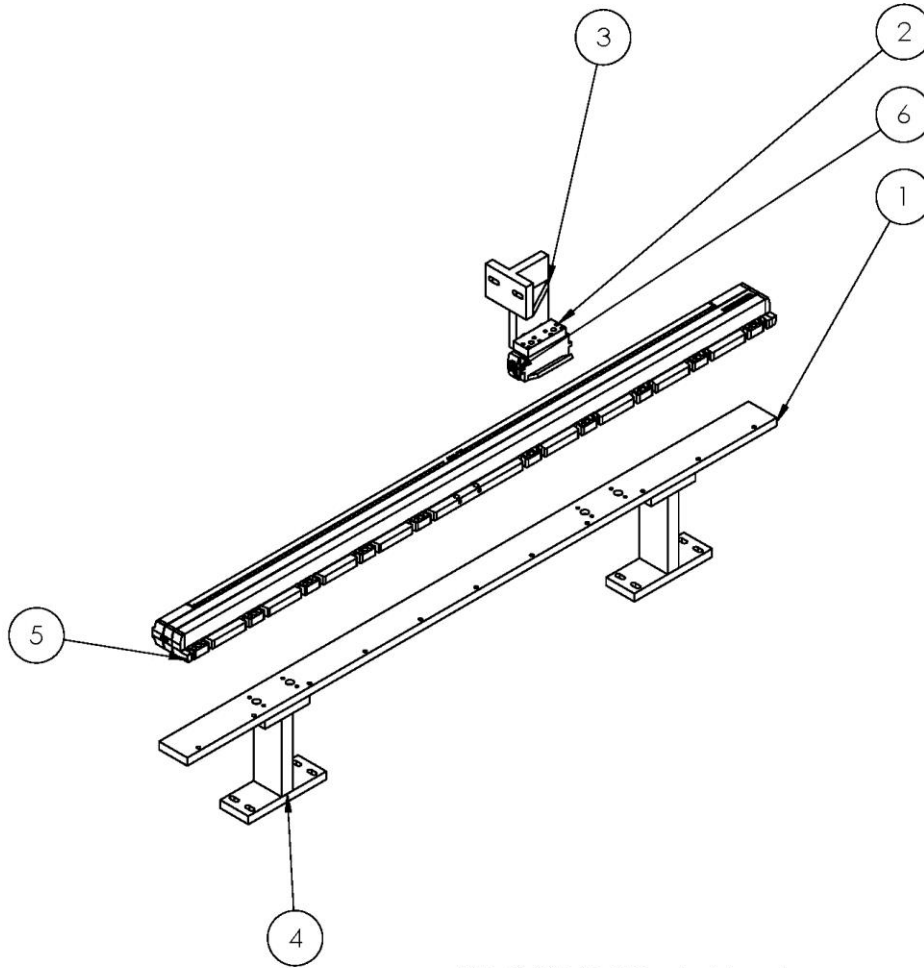

VT-60/VT-80 X Scale Mount

VT-60/80 X Scale Mount

Item No.	Part Name	Q'ty	Jointly part VT-60/80	Do not joint part VT-60/80
1	VT-60 Scale mounting	1		V
2	VT-60 Reader Mount	1	V	
3	VT-60 Reader Mount Upper	1	V	
4	VT-60 Scale Riser	2	V	
5	LC185-940 Scale (VT-80 LC 185-1240)	1		V
6	LC185-940 Scale Reader (VT-80 LC 185-1240)	1		V

6.11 COOLANT TANK DRAWING & PARTS LIST

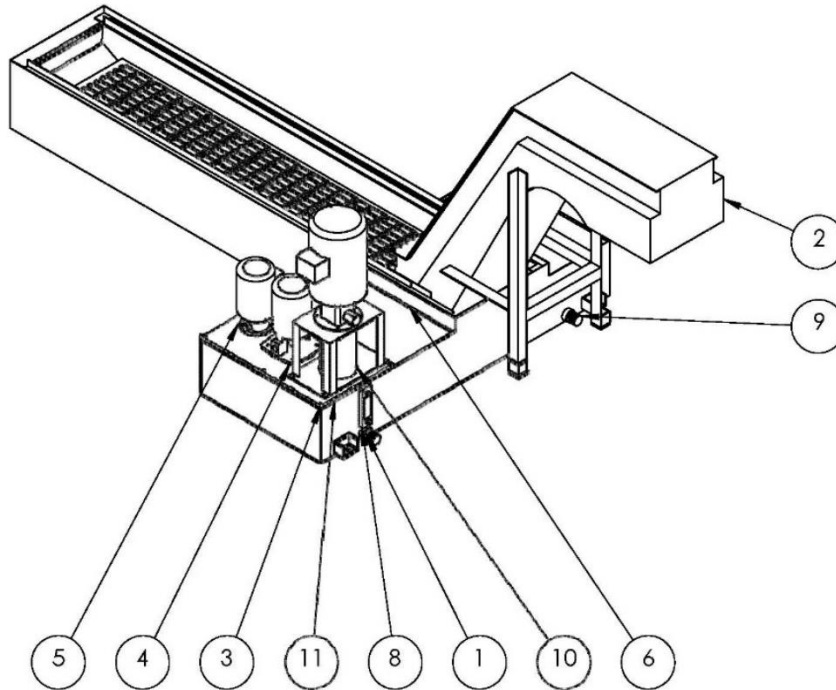

VT-60 Coolant Tank

VT-60 Coolant tank part list

Item No.	Part Name	Part Number	Q'ty
1	VT-60 Coolant tank	VT60 T001	1
2	VT-60 Chip conveyor	VT60T002	1
3	VT-60 Coolant covr 1	VT60T003	1
4	TPAK-8-25 Washdown pump	VT60T004	1
5	TPK2T5-5 Flood pump	VT60T005	1
6	VT-60 Coolant covr 2	VT60T006	2
7	Caster	VT60T007	8
8	Coolant Fluid level	VT60T008	1
9	Plug	VT60T009	2
10	TPRK 3T 26-26 Mount	VT60T010	1
11	TPRK 3T 26-26 Pump	VT60T011	1

6.12 SHEET METAL ASSEMBLY DRAWING & PARTS LIST

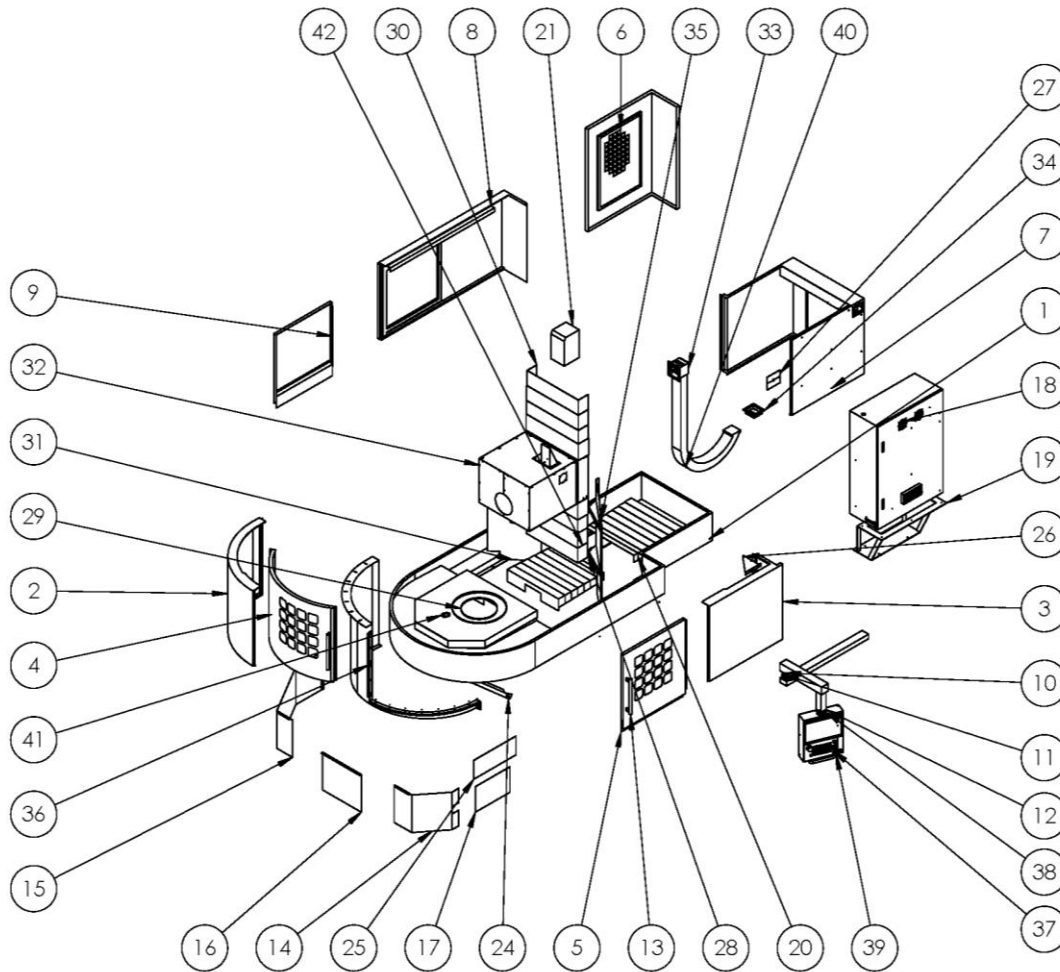

VT-60/80 Sheet Metal Part List

Item No.	Part Name	Q'TY	Jointly part VT-60/80	Do not joint part VT-60/80
1	VT-60 Chip panel R2	1		V
2	VT-60 Front pan R2	1		V
3	VT-60 Right panel R2	1		V
4	VT-60 Front door R2	1		V
5	VT-60 Right Side door R2	1		V
6	VT-60 Left pan 2	1		V
7	VT-60 Rear panel R1	1		V
8	VT-60 Left pan 1	1		V
9	VT-60 Left door 1	1		V

10	VT-60 Steel Bar 3	1		V
11	VT-60 Console rotor	1	V	
12	VT-60 Console arm	1	V	
13	VT-60 Door Handle	2	V	
14	VT-60 Head Right cover R2	1		V
15	VT-60 Head Left cover R2	1		V
16	VT-60 Head Front plate R2	1		V
17	VT-60 Right plate	1		V
18	VT-60 Electrical Cabinet	1	V	
19	VT-60 Electrical Cabinet Mount	1		V
20	VT-60 X Waycover	2		V
21	VT-60 Z motor cover	1	V	
22	VT-60 Front Support Bar 2	1		V
23	VT-60 Spindle motor cover	1		V
24	VT-60 Front Support Bar 1	1		V
25	VT-60 Right plate 2	1		V
26	VT-60 Reinforcement	1		V
27	VT-60 sheet metal 5	2	V	
28	VT-60 Hydraulic tank mount	1	V	
29	VT-60 Chuck ring	1	V	
30	VT-60 Z waycover UPPER	1		V
31	VT-60 Left Wing --SUPPORT	1		V
32	VT-60 HEAD SHEET METAL ASSY	1		V
33	VT 60-80 TRACK BRACKET ASSY	1	V	
34	VT 60-80 TRACK BRACKET REAR	1	V	
35	VT-60 Right Wing-SUPPORT	1		V
36	VT-60 Door Pocket	1		V

37	2300 control Box	1	V	
38	swivel mount	1	V	
39	VT-60 Console Handle	1	V	
40	VT-60 Track 2 R2	1		V
41	VT-60 Chip panel cover R2	1	V	
42	VT-60 Z waycover Down	1		V