



*The Toolroom Company*

**MB-R SERIES  
FRYER / SIEMENS 828 CONTROL  
MAINTENANCE MANUAL**



# TABLE OF CONTENTS

## **1.0 - SAFETY INFORMATION**

Safety Information .....	3
1.01 Mechanical Safety .....	4
1.02 Electrical Safety .....	5

## **2.0 - BASIC INSTALLATION**

### **2.1 WHERE TO PLACE YOUR MACHINE**

2.11 Foundation .....	6
2.12 Environmental Conditions .....	6

### **2.2 UNLOADING YOUR MACHINE** ..... 6

### **2.3 RECEIVING YOUR MACHINE** ..... 6

### **2.4 UNPACK AND PLACE YOUR MACHINE** ..... 7

### **2.5 PRIOR TO THE ARRIVAL OF THE TECHNICIAN**

2.51 Installation Safety Instructions .....	7
2.52 Cleaning & Lubricating Machine .....	7
2.53 Line Voltage Check .....	7
2.54 Electrical Precautions .....	7

### **2.6 LEVELING THE MACHINE**

2.61 Leveling Procedure .....	9
-------------------------------	---

## **3.0 - GENERAL INFORMATION**

### **3.1 MAINTENANCE SCHEDULE CHART** ..... 11

### **3.2 MACHINE COMPONENTS**

3.21 Axis Lubrication System .....	12
3.22 Electrical System .....	12
3.23 Pneumatic System .....	13
3.24 Automatic Tool Changer .....	14
3.25 Spindle .....	14
3.26 Flood Coolant System .....	15
3.27 Fryer Tool Probe .....	16
3.28 Fryer Part Probe .....	17

### **3.3 BASIC MACHINE PROCEDURES**

3.31 Set Axis Home Position .....	18
3.32 Check Axis Backlash .....	19
3.33 Adjusting Backlash Compensation .....	20
3.34 Working with Waycovers .....	20
3.35 Check / Adjusting Ballscrew Endplay .....	21
3.36 Check Axis Belts .....	21

## **4.0 - 828 CONTROL**

### **4.1 ACCESSING MACHINE PARAMETERS** ..... 22

### **4.2 ACCESSING THE SOFTWARE VERSION** ..... 22

### **4.3 REVERT TO THE FACTORY SET PASSWORD** ..... 22

### **4.4 ADJUSTING INPUT VOLTAGE PARAMETERS** ..... 23

### **4.5 M-CODES** ..... 24

### **4.6 ALARMS**

4.61 Siemens Alarms .....	25
4.62 Fryer PLC Alarms and Descriptions .....	25
4.63 Clearing an Alarm .....	26

<b>4.7 WORKING WITH FILES</b>	
4.71 File Types.....	26
4.72 Back-Up An 828 Archive File to A USB Stick.....	26
4.73 Reloading an Archive File .....	27
4.74 Backing Up Tool Data on the 828 Control.....	27
<b>4.8 ADDING A SOFTWARE OPTION TO AN 828 CONTROL .....</b>	<b>28</b>
<b>4.9 SET UP THE NETWORK DRIVE IN AN 828 .....</b>	<b>31</b>

## **5.0 - AUTOMATIC TOOL CHANGER**

<b>5.1 CAROUSEL TYPE ATC OPERATION</b>	
5.11 Safety Rules -- READ BEFORE OPERATING ATC .....	33
5.12 Manual Operation of the Tool Changer.....	33
5.13 Setting Tool Change Height.....	34
5.14 Recovering from a Tool Change Failure.....	35
5.15 Tool Carousel HOME Position and Tool Bin# Reset.....	35
5.16 Spindle Orient Adjustment .....	36

## **6.0 - DRAWINGS AND PARTS LIST**

<b>6.1 828 CONTROL ELECTRICAL PANEL LAYOUT .....</b>	<b>37</b>
<b>6.2 828 CONTROL FRONT PANEL LAYOUT .....</b>	<b>38</b>
<b>6.3 828 CONTROL FRONT PANEL LAYOUT .....</b>	<b>39</b>
<b>6.4 MACHINE BASE AND COLUMN .....</b>	<b>40</b>
<b>6.5 MACHINE COUNTERBALANCE ASSEMBLY .....</b>	<b>42</b>
<b>6.6 MACHINE HEAD ASSEMBLY.....</b>	<b>44</b>
<b>6.7 MACHINE TABLE ASSEMBLY .....</b>	<b>46</b>
<b>6.8 MACHINE SADDLE ASSEMBLY.....</b>	<b>48</b>
<b>6.9 MACHINE X-AXIS ASSEMBLY .....</b>	<b>50</b>
<b>6.10 MACHINE Y-AXIS ASSEMBLY .....</b>	<b>52</b>
<b>6.11 MACHINE Z-AXIS ASSEMBLY .....</b>	<b>54</b>

## 1.0 SAFETY INFORMATION

### READ BEFORE INSTALLING OR OPERATING

***NOTE: THIS MACHINE IS AUTOMATICALLY CONTROLLED AND MAY START AT ANY TIME.***



***All CNC machines contain hazards from rotating parts, belts and pulleys, high voltage electricity, noise, and compressed air. When using CNC machines and their components, basic safety precautions, including all appropriate LOTO procedures must always be followed to reduce the risk of personal injury and mechanical damage.***

It is the machine owner's responsibility to make sure all personnel who are involved in installation and operation of this machine are thoroughly acquainted with the procedures and safety instructions provided herein *BEFORE* they perform any actual work.

Only Fryer factory-trained service personnel should troubleshoot and repair the equipment.

Do not modify or alter this equipment in any way without first consulting Fryer Machine. Any modification or alteration of this equipment could lead to personal injury and/or mechanical damage and could void your warranty.



1. Keep machine and area around it clean and well lit. Never allow chips, coolant, or oil to remain on the floor. Do not leave loose objects on or around machine.
2. Use appropriate eye and ear protection while operating the machine. ANSI-approved impact safety goggles and

OSHA-approved ear protection are recommended to reduce the risks of eye injury and hearing loss.

3. Keep all loose clothing, hair, and jewelry away from the machine at all times.
4. Gloves are easily caught in moving parts. Take them off before using the machine.
5. Always wear safety shoes with steel toes and oil-resistant soles.
6. Do not paint, alter, deface, or remove any warning plates from the machine. Replacement plates are available from Fryer Machine Systems.
7. Keep flammable liquids and materials away from the work area and hot chips.
8. Coolant and oils can make surfaces on the machine slippery. They can also present an electrical hazard if the machine has power on. Therefore, do not stand on any part of the machine at any time.
9. Keep vises, clamps, fixtures, or work pieces from extending beyond the back edge of the table.
10. Check for damaged parts and tools before operating the machine. Any part of a tool that is damaged should be properly repaired or replaced. Do not operate the machine if any component does not appear to be functioning correctly.
11. Improperly clamped parts machined at high speeds/feeds may be ejected and puncture the safety door. Machining oversized or marginally clamped parts is not safe.
12. To avoid tool changer damage, ensure that tools are properly aligned with the spindle drive lugs when loading tools.
13. Windows must be replaced immediately if damaged or severely scratched – contact the factory for replacement panels.
14. Do not attempt to operate the machine before all the installation instructions have been completed.
15. Be sure to review the maintenance section of this manual for instructions to keep your machine running properly.

### **1.01 Mechanical Safety**

1. Always press Emergency Stop when the machine is not in use.
2. Never operate the machine with any cover or shield open or removed.
3. Never reach into the work area when the spindle is turning or if the machine is in automatic mode.
4. Put the machine in manual mode and be sure last programmed function has been completed before reaching inside of the work area.
5. The functions of the machine make it impossible to eliminate all pinch points. Be particularly aware of the following pinch points:
  - a. Spindle and tool rotation
  - b. Indexing of ATC and tools
  - c. Table, saddle, and head.
6. Do not operate machine without axis motor covers or axis waycovers in place.
7. Report any loose, worn, or broken parts to your supervisor. The same action should be taken if any unusual noise or machine action occurs.
8. The electric components are protected from normal moisture resulting from humidity or use of water-based coolants. **DO NOT** however, use a water hose to clean the machine or the area around it.

9. Never touch a machine control device or electrical component when your hand is wet.
10. Never clean up chips while the machine is running or is in automatic mode.
11. Do not file workpieces being rotated under power.
12. At the end of the workday the machine should be placed in "EMERGENCY STOP MODE"
13. When restarting a machine after it has been shut down always assume it has been altered. Recheck all phases of the job as though you were running the first piece.
14. Never run the spindle until hands, feet, and body are well clear of the work area.

### **1.02 Electrical Safety**

1. **WARNING:** Electrical enclosures contain high voltage. Disconnect equipment from power source before opening cabinets.
2. **Before replacing a fuse, switch off the machine.**
3. **Immediately turn off power if:**
  - Power problems develop
  - In the event of electrical storms.
  - Ambient temperatures exceed 105 degrees Fahrenheit (40 degrees C)
4. The electrical power must meet the specifications in this manual. Attempting to run the machine from any other source can cause severe damage and will void the warranty.
5. The electrical panel should always be closed and locked except during service.
6. When the main circuit breaker is on, there is high voltage throughout the electrical panel and some components operate at high temperatures, therefore extreme caution is required.
7. Do not reset a circuit breaker until the reason for the fault is investigated.
8. Never service the machine with the power connected.

## 2.0 BASIC INSTALLATION

### 2.1 WHERE TO PLACE YOUR MACHINE

---

Thank you for choosing Fryer Machine Systems. You have purchased a high quality, custom crafted machine tool designed and built to provide years of trouble-free service. To ensure that your machine is properly installed we ask that you review the following information prior to the shipment of your machine.

#### 2.11 Foundation

Your foundation must be a minimum 6“(150mm) thick concrete slab floor and should be placed on a single slab with no seams. Be sure to leave space around the machine for leveling components and access to the electrical cabinet.

*If your floor does not meet these specifications, contact the factory for further recommendations.*

Install the machine on the first or second floor. Take the stress of ceiling and foundation into careful consideration to ensure that the machine load can be offset.

#### 2.12 Environmental Conditions

Generally, the machine will be installed in the following conditions. However, these may change over a period of time or in response to seasonal changes.

- Supply voltage: +/- 10% of voltage listed on serial number tag.
- Source frequency: ±2 Hz of frequency listed on serial number tag
- Temperature effects dimensional accuracy, therefore, ambient temperatures should not exceed 105 degrees Fahrenheit. Also avoid exposing the machine to direct sunlight or heat rays which can change the environmental temperature.
- Relative Humidity: Less than 80% (Temperature changes should not cause condensation)
- Atmosphere: Free from excessive dust, fumes, corrosive gases, and salt
- Avoid exposing the machine to abnormal vibration.

### 2.2 UNLOADING YOUR MACHINE

---

Fryer machines are shipped on skids designed for forklift offloading. Be sure your forklift is rated for the proper weight of the machine.

**Note:** If you are using a crane for offloading, please contact the factory in advance for instructions as damage can occur if supported in the wrong locations.

### 2.3 RECEIVING YOUR MACHINE

---

**NOTE:** If you have a door that is less than 8' wide x 10' high, please contact the factory prior to shipment so that we can make sure your machine is packaged to fit into your door openings.

1. Fryer machines are carefully packed to avoid damage in transit; however, we ask that you **UNWRAP AND INSPECT YOUR MACHINE AS THOROUGHLY AS POSSIBLE PRIOR TO SIGNING THE BILL OF LADING**. If a digital camera is available, pictures should be taken before the machine is moved further. Pictures should be sent to [service@fryermachine.com](mailto:service@fryermachine.com).
2. Place the machine in its location and complete inspection. If there is any damage to your machine, Fryer should be notified immediately. This will enable us to provide replacement parts before the service technician arrives install the machine.
3. If you have any questions about any of these installation instructions or other questions about your new Fryer Machine Systems machine, please call the Fryer Service Department and one of our trained technical staff will be happy to assist you.

## **2.4 UNPACK AND PLACE YOUR MACHINE**

---

To make certain that your machine installation goes smoothly, it is important that the following items are completed **prior** to the arrival of the Fryer authorized service technician. This will ensure that our technician is able to provide you with the maximum amount of training during his allocated time with you.

1. Have your rigger move the machine to the operating location, remove it from the skid and install on ALL leveling pads.
2. Remove all packaging material and thoroughly clean the machine and inspect for hidden damage.
3. Remove all large assemblies from skids and stage next to machine to facilitate ease of assembly.
4. Install leveling pads and level machine. Level with a precision level, using the leveling screws and pads provided with the machine.

## **2.5 PRIOR TO THE ARRIVAL OF THE TECHNICIAN**

---

### ***2.51 Installation Safety Instructions***

Initial start-up of the machine must be performed by a Fryer Machine Systems authorized service technician.

### ***2.52 Cleaning & Lubricating Machine***

---

All protective coatings (cosmoline) must be removed before using the machine.

Be cautious when selecting a suitable cleaning agent. Paraffin applied with a clean brush will soften the protective coating. The protective coating can then be removed with clean rags.

- WD-40 or a similar product is recommended for cleaning the machine. Do not use gasoline or any other flammable solution to clean the machine.
- Clean all exposed ways of the bed and saddle.

### ***2.53 Line Voltage Check***

---

Line voltage must be  $\pm 10\%$  of the voltage listed on the serial number tag.

**INITIAL POWER-UP SHOULD ONLY BE PERFORMED BY  
A FRYER TECHNICIAN OR FACTORY AUTHORIZED  
REPRESENTATIVE.**

### ***2.54 Electrical Precautions***

---

**ELECTRICAL SCHEMATICS FOR YOUR MACHINE ARE LOCATED IN THE ELECTRICAL CABINET AND IN THIS MANUAL.**

#### **Wiring**

1. Ensure that all local electrical codes are met.
2. Do not connect to the power distribution panel any power cables for devices that can cause line noise, such as welders and high frequency quenching machines.

#### **Grounding**



You should always refer to your local electrical code to be sure you are grounding to code. Generally, use a grounding wire with a cross section of more than 14 mm and a resistance to ground of less than 100 ohms. This wire size should be greater than AWG (American Wire Gauge) No. 5 and SWG (British Legal Standard Wire Gauge) No.6.

Generally, the machine should be grounded to a separate grounding rod. If an independent ground cannot be provided for the machine, prepare the ground connection as follows:

1. Connect a single conductor to its own grounding terminal. This will avoid possible serious accidents resulting from ground currents that might otherwise flow in the NC machine if a peripheral device should malfunction.
2. Be careful when using concrete reinforcing rods as grounding points. These reinforcing rods often are used to ground equipment because they usually offer a resistance to ground of less than 100 ohms. In doing so, make the connection as follows: (This also applies to connecting ground wires to regular grounding terminals)
3. Do not use the same grounding reinforcing rod or grounding terminal for other devices since this could lead to line noise such as produced electric welders and high frequency quenching machines.
4. Use a grounding terminal with an adequate electrical performance rating and which is durable.
5. A separate grounding wire should be used, one whose length is as short as possible.
6. Check the resistance to ground by actual measurement.
7. This should measure less than 100 ohms if the single device is connected to its own grounding rod.

**Desirable Independent Grounding:** Earth resistance: Less than 100 ohms **Common Grounds:**

Resistance to ground =  $100/\text{the number of devices connected to the grounding } (\Omega)$

**NEVER GROUND EQUIPMENT IN SERIES!**

**Connection of Power Line**

**NOTE: Electrical installation should only be completed by a qualified electrician.**

1. Make sure that the incoming power is compatible with the requirements of the machine tool (voltage, amperage, phasing). All this information can be found on the machine's serial number tag.
2. Power wires, grounding and over-voltage protection should comply with the local electrical code.
3. **DO NOT** connect if the incoming power is different from the power requirements of the machine. Contact a qualified electrician.

## 2.6 LEVELING THE MACHINE

---

Before attempting to use the machine, it will be necessary to accurately level it.

- Screw the leveling bolts (with nut) into the holes in the base of the machine. Set a leveling pad under.
- Please prepare the following tools to adjust machine level:
  - Precision level (0.0005"/ft. or 0.013mm/1000mm accuracy)
  - Two adjustable 32mm wrenches
- Clean the bed way and cross slide surfaces thoroughly and set one of the precision levels on the flat bed way in the longitudinal direction, and the other on the cross slide, perpendicular to the first (if there is only one level available, then use it on both directions alternately).
- Adjust the six leveling bolts located the bottom of the machine base until the machine is leveled to within 0.001"/ft. (0.08mm/1000mm) in both directions.
- Lock the nuts on the leveling bolts, and re-check to see whether the level of machine is still correct. Repeat as necessary until machine level is obtained with leveling bolts locked.
- After initial installation, check the level once a week for the first month, then check monthly thereafter.

### 2.61 Leveling Procedure

---

#### Step 1

- Set up your precision level in the middle of the machine table parallel to the X-axis.
- With the table centered in the X and Y-axis, adjust the machine's four outside leveling studs to achieve level.
- Be sure that the center leveling pads are not touching and that all four outside pads have load.
- Also check to make sure that the machine casting is not touching the floor.



#### Step 2

- Now rotate the level 90 degrees so it is parallel to the Y-axis and again check level.
- Adjust the four outside leveling studs as needed.
- If any adjustments are required to achieve level, you must go back and re-check level with the level parallel to the X-axis.
- Repeat the adjustment process until the machine is perfectly level with the level parallel to both axes without further adjustment.



**Step 3**

- Adjust the center leveling studs until they are just touching.
- Again, verify the machine is level with the level parallel to both axes without further adjustment.

**Step 4**

- With the level parallel to the X-axis, slowly move the table back and forth over full Y-axis travel check to see that the level does not change. Make any required adjustments to achieve level.

**Step 5**

- Re-center the table in the Y-axis and again verify that the machine is level with the level parallel to both axes.
- Check that all leveling pads have some degree of load.
- Lock the nuts on the studs once the correct level is achieved.

**Step 6**

- The final check is “trammig” of the head. This is accomplished by mounting the indicator base on the spindle nose and setting the indicator tip on the tabletop at position “0” shown below. Properly load the indicator tip and zero the indicator at position “0”. Sweep the indicator tip by rotating the spindle manually over a 12” diameter circle. The indicator should show no more than .0005” total indicator reading. Record the values found at positions 1, 2, and 3.

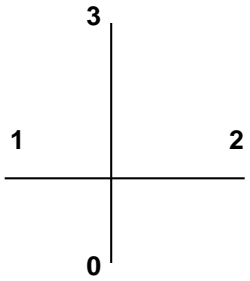
	TABLE SWEEP	 <p>The diagram shows a crosshair with a vertical line and a horizontal line intersecting at the origin. The origin is labeled '0'. The top of the vertical line is labeled '3'. The left end of the horizontal line is labeled '1'. The right end of the horizontal line is labeled '2'.</p>	<p><u>.0005”</u>  <b>OVER 12” DIAMETER</b>  <b>IN X-Y AXIS</b></p>	<p><b>1.</b></p> <hr/> <p><b>2.</b></p> <hr/> <p><b>3.</b></p>

## 3.0 GENERAL INFORMATION

### 3.1 MAINTENANCE SCHEDULE CHART

**\*FOR FURTHER MAINTENANCE DETAIL, REFER TO THE MACHINE COMPONENT SECTIONS IN THE MANUAL LISTED BELOW.**

**CAUTION!** Always follow all Lock Out / Tag Out procedures before performing any maintenance

MAINTENANCE ITEM	RECOMMENDED	Daily	Weekly	6 Mo	As Required
Check air pressure gage	90 – 125 PSI	<b>X</b>			
At the end of the day remove and dispose of chips	Use of brush or vacuum is recommended. Do not use air as it can push chips into waycovers and ballscrews.	<b>X</b>			
Check axis lubrication pump oil level	See Section 3.201 – Use Mobil Vactra #2 (ISO 68) or equivalent	<b>X</b>			
Clean chips from interior of ATC	See Section 3.204 for details		<b>X</b>		
Check pneumatic (air) lubrication oil	Add Mobil ALMO break free synthetic air tool oil (5W-10W)		<b>X</b>		
Check coolant level	Complete a visual inspection		<b>X</b>		
Check machine level	See Section 2.61 for details			<b>X</b>	
Check axis backlash	See procedure in Section 3.43			<b>X</b>	
Remove and clean underside of waycovers / check sliders and bumpers for wear and/or damage	See Section 3.44 for details			<b>X</b>	
Check wipers for adjustment / damage	See Section 3.44 for details			<b>X</b>	
Check ballscrew endplay	See procedure in Section 3.45			<b>X</b>	
Check axis motor belts	See procedure in Section 3.46			<b>X</b>	
Grease ATC cam pockets	See Section 3.24 for details			<b>X</b>	
Change coolant	Blasocut BC40 NF-PL or equivalent				<b>X</b>
Check and change electrical cabinet air filters	Use Purolator A23465 air filters				<b>X</b>

## 3.2 MACHINE COMPONENTS

### 3.21 Axis Lubrication System

- The automatic way lube system is controlled by the PLC in the control. The system only pumps way oil when the spindle and axes are moving. If there is no machine movement the pump will not pump unnecessary oil. This method greatly reduces way lube usage and keeps oil out of the machine coolant sump and prevents fouling.



- If the machine has been unused for more than 48 hours press the blue pushbutton on the side of the lube tank for approximately 30 seconds to pump oil to the ways. The pressure gage on the tank will indicate if it is working properly.
- If the system detects low way lube it will display the following message in the control: 700040 - WAY OILER PRESSURE FAULT

### 3.22 Electrical System

- Schematics (1) – The Electrical and Pneumatic Schematics are inside electrical cabinet
- Cabinet Filter Type (2) – Purolator A23465 or equivalent
- Check Filter Interval - Weekly
- Change Filter Interval – As Required (depending on environment)



### 3.23 Pneumatic System

---



- Schematic – See Pneumatic Schematic in electrical cabinet (see previous page)
- Pneumatic List / Pressure Settings
  - Main Supply – 90-125 PSI at 5 CFM
  - Air Gun
  - Tool changer – Carousel In
  - Tool changer – Carousel out
  - Spindle Air Blast (Taper Cleaning Air) – Adjustable (Factory Set)
  - Drawbar Solenoid
  - 4<sup>th</sup> Axis Brake (optional)
  - Spray Mist – Adjustable on spray mist unit (optional)
  - Programmable Air Blast – Adjustable (optional)
  - X, Y, Z Glass Scale Purge – Set Regulator to 11.6–17.4 PSI
- Lubrication Requirements – Mobil Almo break free synthetic air tool oil 5W-10W or equivalent
- Check Lubrication Interval – Weekly – Add as needed

### 3.24 Automatic Tool Changer – CAT40 / BT40 – 12 or 20 Position, Carousel Style Automatic Tool Changer

---

- Maximum Tool Diameter – 3.20”
- Maximum Tool Diameter with adjacent positions empty – 5.50”
- Maximum Tool Length – 11.80”
- Maximum Tool Weight – 15.4 lbs.
- Tool Carousel Maintenance
  - Keep all tool grab fingers clean and free of debris.
  - Clean all chips from the interior of the ATC daily. Take care to make sure the proximity switches and the cam / cam pockets are free of chip contamination.
  - Grease the cam pockets every 6 months (see picture below).



- Tool Changer Pneumatics
  - Tool carousel in and tool carousel out is controlled pneumatically.
  - Setting Tool Change Height – See Section 5.14 Setting Tool Change Height procedure
  - Setting Spindle Orient – See Section 5.17 Spindle Orient Adjustment Procedure

### 3.25 Spindle – CAT40 / BT40 - 8,000 RPM Spindle

---

Thermal expansion of the machine components can jeopardize machining accuracy. To prevent this condition always warm the machine up.

*SPINDLE WARM UP* – Use the chart below for daily startup

Warm Up Cycle	10 minutes @ 25% of maximum speed
	10 minutes @ 50% of maximum speed
	10 minutes @ 75% of maximum speed

*SPINDLE DUTY RATING* – Follow the duty rating outlined below

- If it is required for the spindle to run continuously (24 hours a day), the spindle must not run above 80% of the maximum RPM.
- If it is required for the spindle to run at maximum RPM, the spindle must not run more than 2 hours straight. After 2 hours of run time at maximum RPM, the spindle must be slowed down to 50% of the maximum RPM for at least 30 minutes before running at the maximum RPM again.

### 3.26 Flood Coolant System

---

The flood coolant system consists of a submersible flood pump mounted in the base casting of the machine. The flood line runs up the back of the column and through the Z-axis cable track. It splits at a y-fitting in the headstock where it runs to two separate lengths of loc-line.

- The submersible flood pump is mounted behind the access panel shown below.
- The sump can be drained for coolant changes by using a wet vacuum.





### 3.27 Fryer Tool Setter (Tool Probe)

The Fryer Tool Probe can only be used to automatically measure tool length. It cannot be used to measure tool diameter or radius. Optional tool setting probes are available to perform length and diameter or radius measurements.

#### Tool Setter Calibration

If you ordered the tool probe during the original build of the machine it will have already been mounted to the machine table and tested at the factory. However, it must be calibrated before using it to set up your tool length offsets.

1. Install the tool probe in the reamed hole in the table and make sure that it is plugged in.
2. Set up a tool holder with a 1/2" dowel pin installed.
3. Use the **NEW TOOL** key to create the setup tool in the tool library as a 1/2" tool using the default name **CALIBRATION TOOL**.



10	CALIBRATION TOOL	1	1	0	-18.5250	0.5000	⊗
----	------------------	---	---	---	----------	--------	---

4. Complete a tool change to this tool so that it will be active in the control.
5. Set a negative tool length offset for the **CALIBRATION TOOL** by measuring the distance from the tip of the dowel (while Z is at machine zero) to the top of the table surface.
6. Make sure your active work offset is zero in the Z-Axis.
7. Use paper, shim stock, or a gauge block to touch the dowel to the table.
8. Press **MEASURE TOOL** key
9. Press **LENGTH MANUALLY** key
10. Select **WORKPIECE**
11. Type the thickness of the paper, shim, or gauge block into Z0
12. Press **SET LENGTH** key

Now position the dowel approximately 1/4" above the probe in Z and roughly over the center of the probe

1. Select **MEASURE TOOL**
2. Select **CALIBRATE PROBE**
3. Select **LENGTH ONLY**
4. Press **CYCLE START**
5. The tool will move down in the Z axis and touch the top of the probe.
6. Once finished the tool will move back up.
7. Select **BACK** twice to exit the calibration screen and go to the **MANUAL** screen.

Calibration is now complete.



### 3.28 Fryer Part Probe

The Fryer Part Probe can only be used to automatically measure X and Y axis positions. It cannot be used to measure in the Z axis. Optional part probes are available to perform 3-axis measurements.

If you ordered the part probe during the original build of the machine it is located in the tool library where manual tools are stored. However, it must be calibrated before using it to set up your work offsets.

#### Fryer Part Probe Calibration

1. To set up a new FRYER probe in the tool table, it needs to be in the manual tool location in the library. It is important to remember your probe is wired which is manually inserted and removed the tool from the spindle.
2. Define the tool as a **3D probe**. When adding the new tool, you will need to press the **other** button to access the **3D** tool option. It is important that you fill out the correct tool diameter.

	3D_PROBE	1	1	0	-20.5340	0.3938	
-----------------------------------------------------------------------------------	----------	---	---	---	----------	--------	------------------------------------------------------------------------------------

3. Load the probe into the spindle. Make sure the control recognizes the probe.
4. A ring gage is required for this next step. (A 2" diameter gage is recommended).
5. If a different diameter is required, change parameter **MD51770** to change diameter dimension. Refer to Section 4.1 for directions to access parameter screens.
6. Mount the gage to the machine table and use an indicator to find the center of the gage.
7. Once in the center, set a work offset in the middle. Make sure the offset is called up in the control.
8. Position the part probe at X and Y zero (middle of the gage). The Z axis should be roughly 1/4" below the top of the ring gage.
9. Select **WORKP. ZERO**
10. Select **CALIBRATE PROBE**
11. Select **DIAMETER**. The diameter value must equal the diameter of your gage.
12. Press **CYCLE START**. Once complete the probe should be calibrated in the X and Y axis.
13. At this point the part probe is calibrated and ready for use.
14. Remove the ring gage and store it in a safe place.



### 3.3 BASIC MACHINE PROCEDURES

---

#### 3.31 Setting Axes Home Positions

#### PROCEDURE TO BE PERFORMED BY QUALIFIED PERSONNEL ONLY

The 828 control comes standard with absolute encoders which generally do not require homing. However, if you have an issue with the battery or the machine is not turned on for an extended length of time the machine may need to be re-homed according to the following procedure. In addition, if an axis motor is removed or there is an issue with a motor coupling or pulley / belt assembly, one or more axes may need to be re-homed.

- Refer to Section 4.1 for directions to access parameter screens.
  1. Press **MENU SELECT**
  2. Select **SETUP**
  3. Select **MACHINE DATA**
  4. Select **AXIS MD**
  5. Select **SEARCH**
  6. Enter **34210 [0]** in the search field (This will read **ENC\_REFP\_STATE**)
  7. Select **OK**
  8. Select the proper axis with the **AXIS + AND AXIS -**
  9. Change the parameter **34210 [0] to 0** for an axis with a motor encoder
  10. Change the parameters **34210 [0]** and **34210 [1] to 0** for an axis with a scale
  11. Press **INPUT**
  12. Cycle power to machine leaving it off for a minimum of 30 seconds
  13. **Take extreme caution now as the machine can be crashed!**
  14. Line up the home markers for all axes that need to be homed
  15. Press the **E-STOP** button to turn off the servos
  16. Press **MENU SELECT**
  17. Select **SETUP**
  18. Select **MACHINE DATA**
  19. Select **AXIS MD**
  20. Select **SEARCH**
  21. Enter **34210 [0]** in the search field (This will read **ENC\_REFP\_STATE**)
  22. Select **OK**
  23. Select the proper axis with the **AXIS + AND AXIS -**
  24. Make sure Parameter **34210 [0]** and **34210 [1]** (if axis has a scale) **are set to 0**. If it is not, it is probable that the wrong axis is selected.
  25. Change the parameter **34210 [0] to 1** for an axis with a motor encoder
  26. Change the parameters **34210 [0]** and **34210 [1] to 1** for an axis with a scale
  27. Press **INPUT**
  28. Turn the feed rate override all the way down
  29. Pull the **E-Stop** button out
  30. Select **RESET**
  31. Press **HOME RETURN** (should say Jog Ref at the top of the screen)
  32. For a mill, press **AXIS+** (refers to the hard key on the manual panel you have selected)

33. When done make sure parameter **34210 [0] shows 2** for all axes (axis with motor encoder)
34. When done make sure parameter **34210 [0]** and parameter **34210 [1] shows 2** for all axes (axis with scale)

### **3.32 Check Axis Backlash**

---

Tools Required: 0.0001" resolution dial indicator, remote handwheel (manual pulse generator)

- Set the indicator along the axis which is being measured. The needle should be in contact with a flat machined surface and the base on a stable, fixed point. See the pictures below which illustrate the setup for the X, Y, and Z axes.
- Using the remote handwheel, move the axis in one direction either positive or negative until the indicator is loaded by 0.002".
- Zero the indicator.
- Move the axis in the same direction by 0.005".
- Reverse the direction of the axis by 0.005".
- The additional amount that is needed to reach zero after the 0.005" reverse in direction is the backlash measured.
- This shows the loss of motion in the axis from the ballscrew and linear guide rails. Backlash compensation can be adjusted according to the procedure outlined below in *Section 3.33*.

X-Axis



Y-Axis



Z-Axis



### 3.33 Adjusting Backlash Compensation

---

#### PROCEDURE TO BE PERFORMED BY QUALIFIED PERSONNEL ONLY

- Refer to Section 4.1 for directions to access parameter screens.
  - Press **MENU SELECT**
  - Select **SETUP**
  - Select **MACHINE DATA**
  - Select **AXIS MD**
  - Using **AXIS+ AND AXIS-**, select the correct axis
  - Select **SEARCH**
  - Enter **32450 [0] or 32450 [1]** if the machine is equipped with glass scales on the selected axis
  - Adjust the backlash on each axis
  - Select **SET MD ACTIVE (cf)**
  - Select **RESET (po)** to reboot the control

### 3.34 Working With Waycovers

---

- When working with steel waycovers, several precautions must be taken:
- Do not put excessive weight on the waycovers (50lbs. max.)
- Protective gloves should be worn while handling waycovers, as the metal edges can be sharp.
- Covers should be cleaned regularly to avoid any build-up of chips or debris. It is recommended that the underside of the covers be thoroughly cleaned at least every 6 months.

To remove the waycovers for service:

- Jog the axis being worked on so that the cover to be removed is in the fully compressed position.
- Next, remove the cap head screws attaching the cover to the moving axis and to the waycover standoff (if applicable).
- The waycover can now be removed by simply pulling it off the way surface.

To check waycovers for wear and/or damage:

- Make sure the covers slide open and closed freely and that there are no dents or visible damage that would impair free movement of the covers.
- Inspect the plastic sliders and rubber bumpers under the waycover to make sure they are in place and not damaged or worn.

To reinstall the waycovers on the machine:

- Slide the cover on the appropriate way surface making sure that it is clear of debris.
- Insert the cap head screws to the moving axis and the standoffs (if applicable) and **hand tighten only**.
- To properly align the waycover, jog the axis to the position where the waycover is in full extension, and then full compression.
- With the waycover fully compressed, all cap head screws can now be tightened.
- Run the axis back and forth slowing over full travel check for any visual signs of misalignment.
- Now rapid the axis back and forth over full travel again check for any signs of misalignment.

### **3.35 Check / Adjusting Ballscrew Endplay**

---

\* It is important to read and understand the procedure *3.34 Working with Waycovers*, before executing this procedure.

- Tools Required: 0.0001" resolution dial indicator, remote handwheel (manual pulse generator), metric allen key set, spanner wrench.
- Check Endplay: You will need to access the pulley end of the ballscrew for the axis being worked on. To do this, remove the left side waycover and the belt cover for the X-axis. Remove the front waycover and belt cover for the Y-axis. The top end of the z-axis ballscrew is accessible by just moving the head down. Place a dial indicator needle on the end of the ballscrew. Load and zero the indicator appropriately. Using the remote handwheel set to x100 for the appropriate axis, change axis direction back and forth and observe any axial motion shown on the indicator. Endplay should be no more than .0001". This can also be accomplished by jogging each axis using the manual panel buttons or manually by using an allen wrench on the end of the ballscrew.
- Adjusting Endplay: If ballscrew endplay is greater than 0.0001", it must be adjusted. To do so, loosen the 3 set screws on the ballscrew spanner nut adjacent to the motor coupling. Using a spanner wrench, tighten the nut. The ballscrew will have to be held stationary with an allen key on the opposite end. Tighten the set screws and recheck the endplay. Repeat the tightening procedure if necessary. Once the ballscrew endplay is .0001" or less, re-install any sheet metal or motor covers and re-install the waycover(s) as applicable.

### **3.36 Check Axis Motor Belts**

---

- The axis motors are connected to the ballscrews via pulley driven belts. Belts should be checked for excessive wear and proper tension at least every 6 months.
- To access the belts, remove left side belt cover for the X-axis and the front belt cover for the Y-axis.
- The Z-axis belt is located on the top of the column
- Once you have gained access to the belts, inspect them for any visible signs or wear or damage. Once the belts are considered acceptable, check each belt for proper tension.
- Belt tension is adjusted by loosening the slotted motor plate and sliding the motor-plate assembly to tighten or loosen the belt as required. Double check all hardware is properly tightened once the belt tension is correct.
- After the inspection is complete and any adjustments made, re-install the belt covers.

## 4.0 828 CONTROL

### 4.1 ACCESSING MACHINE PARAMETERS

---

#### PROCEDURE TO BE PERFORMED BY QUALIFIED PERSONNEL ONLY

 <b>WARNING</b>
<b>Malfunctions of the machine as a result of incorrect or changed parameter settings</b>
As a result of incorrect or changed parameterization, machines can malfunction, which in turn can lead to injuries or death.
<ul style="list-style-type: none"><li>• Protect the parameterization (parameter assignments) against unauthorized access.</li><li>• Handle possible malfunctions by taking suitable measures, e.g. emergency stop or emergency off.</li></ul>

1. Press **MENU SELECT**
2. Select **SETUP**
3. Select **MACHINE DATA**
4. Available folders: **GENERAL MD / CHANNEL MD / AXIS MD**

### 4.2 ACCESSING THE SOFTWARE VERSION

---

To find out the version of the software you are running on your 828 control:

1. Press **MENU SELECT**
2. Select **DIAGNOSIS**
3. Select **VERSION**
4. The Software Version number is on the first line and will read: "**V##.## + SP ## + HF ##**"

### 4.3 REVERT TO THE FACTORY SET PASSWORD

---

#### PROCEDURE TO BE PERFORMED BY QUALIFIED PERSONNEL ONLY

1. Press **MENU SELECT**
2. Select **SETUP**
3. Select **SET PASSWORD**
4. Enter the password: **SUNRISE**
5. Press **OK**
6. The lower part of the screen should now read "Current Access Level: Manufacturer"

## 4.4 ADJUSTING INPUT VOLTAGE PARAMETERS

### PROCEDURE TO BE PERFORMED BY QUALIFIED PERSONNEL ONLY

The Siemens control will shut itself off if the line voltage is more than 10% different than the voltage set in the control. You must adjust the parameter to match your line voltage to the machine.

The first step to accurately measure your line voltage. There are two ways to do this.

- Measure the incoming line voltage across all three legs with a voltmeter. Average your readings and write down the value.
  - OR -
- Read the line voltage from the control, follow the following steps:
  - **MENU SELECT** key
  - **SETUP** key
  - **INFEED PARAMETER** key
  - Find **r25[0]** = and write down the voltage value in this parameter.
- Now you have the proper line voltage value to enter in the control.

Follow the steps below:

- Press E-stop
- **MENU SELECT** key
- **SETUP** key
- Press  $\wedge$  (up arrow hard key next to machine hard key)
- **DRIVE SYSTEM** key
- **SUPPLY** key
- **POWER DATA** key See screen below:

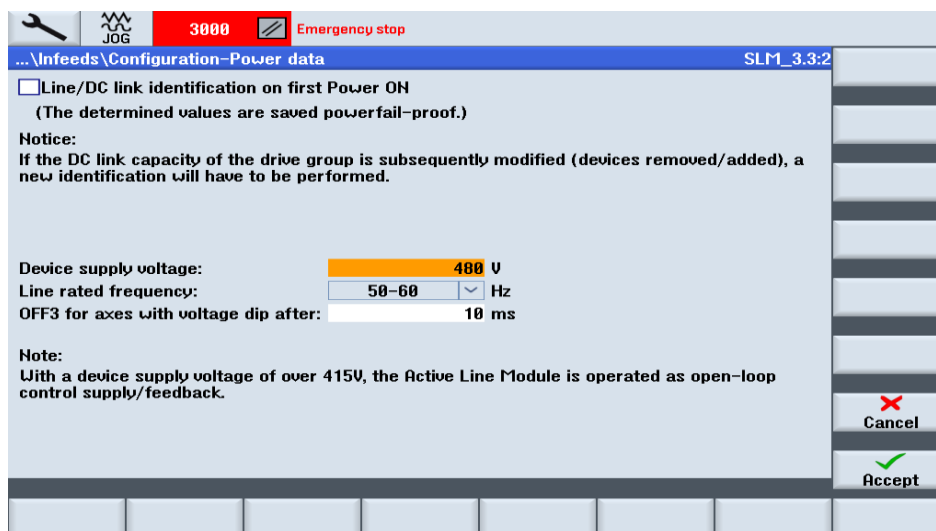

- Scroll down to the **Device Supply Voltage** field like in the screen shot above. Enter the line voltage value you obtained in the previous steps, press enter
- Press **ACCEPT** key
- There will be a message that states, "Confirm You Want to Change the Parameter", Press **YES** key to accept the change



## 4.5 M-CODES

---

An M code in CNC programming controls miscellaneous machine functions, including starting and stopping specific actions or programs.

M00	PROGRAM STOP
M01	OPTIONAL PROGRAM STOP
M02	END OF PROGRAM
M03	SPINDLE CLOCKWISE
M04	SPINDLE COUNTERCLOCKWISE
M05	SPINDLE STOP
M06	TOOL CHANGE REQUESTED
M07	MIST COOLANT / AIR BLAST ON
M08	FLOOD COOLANT
M09	COOLANT (FLOOD AND MIST / AIR BLAST) OFF
M10	INDEXER CYCLE START WAIT FOR COMPLETION
M11	MISC. MCODE M11=ON
M12	MISC. MCODE M12=OFF
M13	A AXIS BRAKE ON
M14	A AXIS BRAKE OFF
M17	END OF MACRO PROGRAM
M19	SPINDLE ORIENT
M23	2ND PROGRAMMABLE AIR BLAST ON
M24	2ND PROGRAMMABLE AIR BLAST OFF
M25	TURNS ON PART PROBE (MARPOSS / RENISHAW )
M26	TURNS OFF PART/TOOL PROBE (MARPOSS / RENISHAW )
M27	TURNS ON TOOL PROBE (MARPOSS / RENISHAW )
M30	END OF PROGRAM
M52	ATC CAROUSEL IN
M53	ATC CAROUSEL OUT
M54	DRAWBAR ON
M55	DRAWBAR OFF
M58	ATC CAROUSEL CW 1 POSITION
M59	ATC CAROUSEL CCW 1 POSITION
M61	HOME ATC CAROUSEL TO POCKET 1, ASSUMES TOOL 0 IN SPINDLE

Note: M-codes may change depending on options the machine is equipped with.

## 4.6 ALARMS

---

An alarm will be displayed once a fault occurs.

**!** *Warning: If you do not heed an alarm that is issued and do not resolve the cause of the alarm, it can present a hazard to the machine, the work piece, the saved settings, and in certain circumstances, may cause injury.*

### 4.61 Siemens Alarms

---

1. If a familiar alarm number / description appears carefully check the machine and resolve the cause of the alarm.
2. If you are unfamiliar with the alarm in question, proceed to the alarm list as follows:
  - a. Press **MENU SELECT**
  - b. Select **DIAGNOSTICS**
  - c. Select **ALARM LIST**
3. \*Once "**ALARM LIST**" has been selected, press **HELP** key and additional information will be provided on the control screen.

### 4.62 Fryer PLC Alarms and Descriptions

---

There are certain PLC alarms in the 700000 range which are not in the **HELP** screen. These are FRYER Machine specific alarms that are for optional equipment installed on the machine. The alarms are listed below:

700000	ATC CAROUSEL NOT REFERENCED: EXECUTE M61
700001	LOW WAY LUBE [I32.6]
700002	LOW AIR PRESSURE [I32.2]
700003	HOME REQUIRED! PRESS CYCLE START
700004	PROBE ERROR / SIGNAL LOSS
700005	GEAR CHANGE FAULT
700006	SPINDLE OUT OF GEAR
700008	CHILLER FAULT
700009	HYDRAULIC PRESSURE FAULT
700011	THRU SPINDLE COOLANT FAULT, CHECK COOLANT SUPPLY
700013	EMERGENCY STOP PRESSED DURING TOOL CHANGE
700014	COUNTER-BALANCE CYLINDER PRESSURE LOW!
700015	ATC CAROUSEL TIMED OUT-CHECK THERMAL MCCAR
700016	CAROUSEL CANNOT INDEX POT NOT RETRACTED
700024	M52-TOOL POT DOWN TIMED OUT
700025	M53-TOOL POT UP TIMED OUT
700026	M69 CAUSED SERVO OFF
700027	M62 TIMED OUT CHECK TC HEIGHT,ORIENT,THERMAL MCATC
700028	M63 TIMED OUT CHECK THERMAL MCATC
700029	M54 DRAWBAR ON TIMED OUT
700030	M55 DRAWBAR OFF TIMED OUT
700032	CONTOUR HANDWHEEL ACTIVE
700033	Z MOTION AND ATC ARM NOT AT HOME POSITION
700034	RESET SUPPRESSED UNTIL TOOL CHANGE COMPLETION
700035	HOME RETURN: DEPRESS CYCLE START
700037	REPLACE PROBE BATTERY
700038	TOOL SETTER ACTIVE
700039	PART PROBE ACTIVE
700040	WAY OILER PRESSURE FAULT
700041	DOOR IS OPEN ~ CLOSE DOOR; PRESS CYCLE START TO CONTINUE

- 700042 Y AXIS MOTION AND ATC ARM NOT AT HOME POSITION
- 700043 DRAWBAR FAILURE
- 700044 QUILL SCALE POSITION UPDATE ON PRESS BUTTON AGAIN TO TURN OFF

#### 4.63 Clearing an Alarm

---

1. Carefully check the machine according to the description given in the alarm. Clarification of the alarm codes can be found by using the **HELP** as described above.
2. Resolve the cause of the alarm.
3. Press **RESET**
4. Certain alarms will require a reboot of the control to clear.

### 4.7 WORKING WITH FILES

---

#### 4.71 File Types

---

- **NC** archive contains the machine **PARAMETERS**
- **PLC** archive contains the **LADDER LOGIC** for the machine functions
- **DRV** archive contains the **AXIS DRIVE SETTINGS**

#### 4.72 Back-Up An 828 Archive File to A USB Stick

---

For a download of the machine archive to a USB , press these three keys at the same time on the control:

**CTRL + ALT + S**

This will create a complete standard Easy Archive (**.ARD**) on a **USB**.

---

If a specific file or additional files need to be backed up to a **USB**, do the following:

#### PROCEDURE TO BE PERFORMED BY QUALIFIED PERSONNEL ONLY

1. Select the **MENU SELECT**.
2. Select the **STARTUP**.
3. Press the **SYSTEM DATA** key. The data tree will open.
  - i. In the data tree, select the required files from which you want to generate an archive.
4. Press the **ARCHIVE** and **GENERATE ARCHIVE** keys.
5. The **GENERATE ARCHIVE: SELECT STORAGE LOCATION** window opens. Select the **USB** location for archiving.
6. Save the file as serial number of machine and the file name (i.e., for drive archive: "25123DRV")
7. Enter a name and press the **OK** key. The directory is created below the selected folder.
8. Press the **OK** key.
9. Select the format archive **ARD** for 828, enter the desired name and press the **OK** key to archive the file/files.
  - a. A message informs you if archiving was successful.
10. Press the **OK** key to confirm.
11. An archive file in the **.ARD** (828) format type is created in the selected directory.

\*Note: When backing up an entire machine you should generate an individual file for NC, PLC, Drive, and HMI. When that step is completed, you should generate an archive for all these together.

#### 4.73 Reloading an Archive File

---

### PROCEDURE TO BE PERFORMED BY QUALIFIED PERSONNEL ONLY

**NOTE:** Set the password protection to “Current Access Level: Manufacturer”. Refer to Section 4.3 above.

1. Select the **PROGRAM MANAGER** key.
2. Press the **ARCHIVE** and **READ IN ARCHIVE** keys.
3. Select the archive storage location (i.e., **USB**) and position the cursor on the required archive.
4. Note: When the option is not set, the folder for user archives is only displayed if the folder contains at least one archive.

OR

5. Press the **SEARCH** key and in the search dialog, enter the name of the archive file with file extension **ARD** if you wish to search for a specific archive and press the **OK** key.
6. Press the **OK** or **OVERWRITE ALL** key to overwrite existing files.

OR

7. Press the **DO NOT OVERWRITE** key if you do not want to overwrite already existing files.

OR

8. Press the **SKIP** key if the read-in operation is to be continued with the next file.
9. The **READ IN ARCHIVE** window opens and a progress message box appears for the read-in process.
10. You will then obtain a **READ ERROR LOG FOR ARCHIVE** in which the skipped or overwritten files are listed.
11. Press the **CANCEL** key to cancel the read-in process.

\*Note: You may only archive one file at a time.

#### 4.74 Backing Up Tool Data on the 828 Control

---

Note: Setup data from part programs can only be backed up if they have been saved in the **WORKPIECES** directory.

For part programs, which are located in the **PART PROGRAMS** directory, **SAVE SETUP DATA** is not listed.

1. Select the **PROGRAM MANAGER** operating area.
2. Position the cursor on the program whose tool and zero-point data you wish to back up.
3. Press the **>>** and **ARCHIVE** keys.
4. Press the **SETUP DATA** key.
5. The **BACKUP SETUP DATA** window opens. Select the data you want to back up.
6. Change the specified name of the originally selected program in the **FILE NAME** field, if needed.
7. Press the **OK** key.
8. The setup data will be set up in the same directory in which the selected program is stored as an INI file.

## 4.8 ADDING A SOFTWARE OPTION ON THE 828 CONTROL

When you receive your machine all license numbers applicable to your order are activated prior to the machine leaving the factory. If you purchase a control option after the machine arrives at your facility you will receive a license number to active on your control. The license will either require you to go online and create a new license key, or this will be already done for you. If you receive a license certificate like pictured in figure one go to step 1, if not and you already have a license ( see figure 2) then proceed to step 8 .

1. You need to obtain the hardware serial # (this not the same as the control serial number) follow these steps:

- Press **MENU SELECT**
- Press **SETUP**
- Select **LICENSE** (you may have to press the ^ or > key to see the soft key)
- Record the **CF CARD SERIAL #**

This number can also be found in the CF card located in your electrical cabinet. The number on the card is labeled as CFC SN. **CAUTION:** Machine must be powered down before the card is removed.

2. Once you have obtained your Control Hardware Serial Number you are ready to activate your new license number. Using the internet, log onto: [www.Siemens.com/Automation/License](http://www.Siemens.com/Automation/License)

- Click on the link for **DIRECT ACCESS**
- Enter the **LICENSE # AND DISPATCH NOTE #** from the paperwork into the areas indicated on the web page.



3. Click **NEXT**
4. On the next screen enter your hardware serial number.
5. Next select the control model. Your machine has a 828.
6. The system will now return a software license key
7. Download PDF and save for your records. Also print the PDF so you can refer to it at the machine to type in new license key.
8. Already have printed license see below:



- Follow step 1 to get to the license screen. Type in (overwriting old license key) current license key and press input. The field is highlighted, make sure to enter correctly.

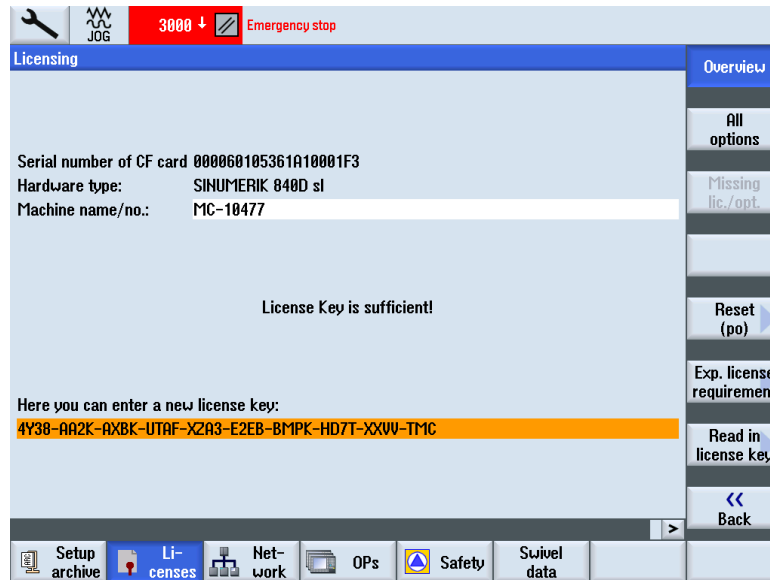

Figure 3

- Press all options soft key
- Search for the particular option you want to activate. Set the box with the select key. See figure 4.

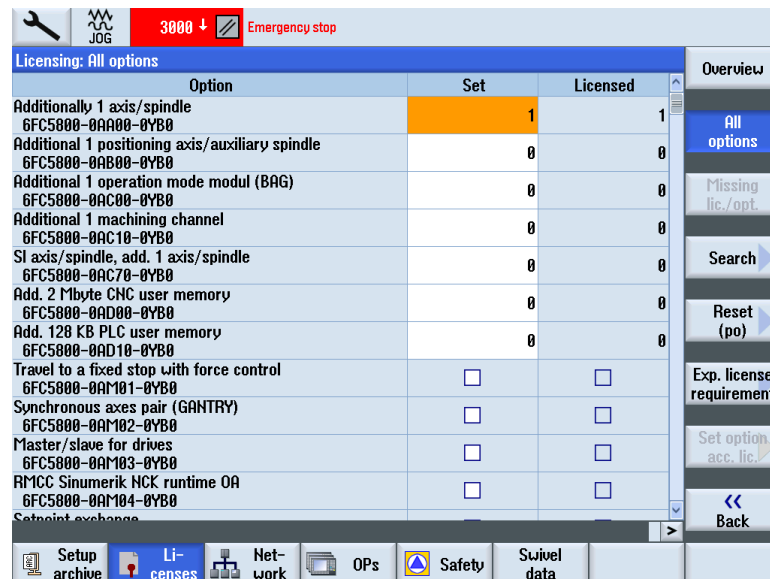

Figure 4

- Press back soft key and power machine down. When you turn the machine back on the option should be activated.

## 4.9 SET UP THE NETWORK DRIVE IN THE 828

**! NOTE:** *It is recommended that this procedure be performed by an experienced network administrator.*

The transfer of programs can be achieved by mapping a soft- key to a networked computer. The soft key will appear in the Program Manager screen of the controller.

The computer connected to the network must be configured with a unique username and password. This information will be required for inputting on the controller. A dedicated shared folder is required on the PC for the storage of files.

- Refer to Section 4.1 for directions to access parameter screens.

1. Press **MENU SELECT**
2. Select **SETUP**
3. Select **START-UP**

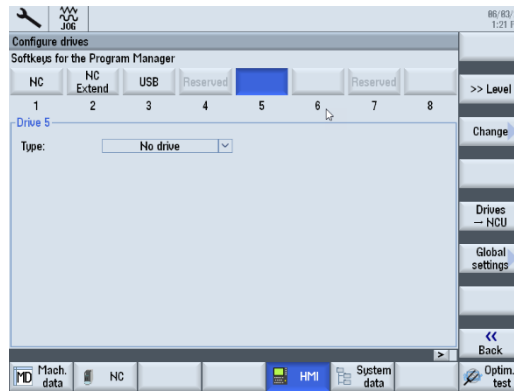

4. Press the **HMI** and **LOG. DRIVE** keys. The **SET UP DRIVES** window opens.
5. Select the open key that you want to configure (**example #5**).
6. To allow entry fields to be edited, press the **CHANGE** key.
7. Select the data for the corresponding drive or enter the necessary data.

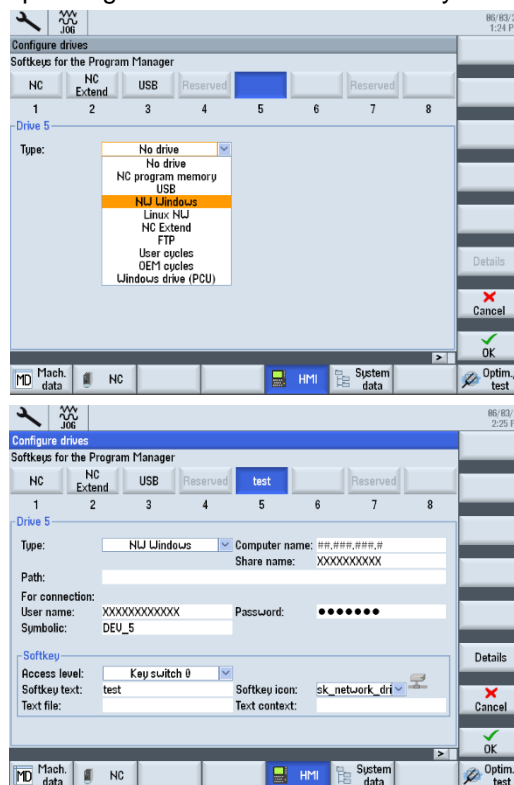

8. Press the **OK** key. The entries are checked. A window with the appropriate message opens if the data is incomplete or incorrect. Acknowledge the message with **OK** key. If you press the **CANCEL** key, then all of the data that has not been activated is rejected.
9. Restart the control in order to activate the configuration and to obtain the keys in the **PROGRAM MANAGER** screen.





## 5.0 ATC OPERATION

### 5.1 CAROUSEL TYPE ATC OPERATION

#### 5.11 Safety Rules -- READ BEFORE OPERATING ATC

**CAUTION!** Always follow all Lock Out Tag Out procedures before performing any maintenance

- Due to the complexity and timing of the ATC, it should only be operated with the **M6** command.
- **Never interrupt the tool changer in the middle of cycle, wait for it to complete the tool change.**
- The carousel motor is a 3-phase motor and must be phased correctly for proper direction. The machine is phased properly at the factory before shipment, so if the carousel rotates in the wrong direction, switch any two incoming power wires at the disconnect. **Make sure the main power breaker is off!**
- **M58** moves carousel position CW one position, **M59** moves carousel position CCW one position.
- If the T code is programmed on the same line as the M6 command, make sure the M6 is before the T code (example: M6T4).

#### 5.12 Manual Operation of the Tool Changer

##### PROCEDURE TO BE PERFORMED BY QUALIFIED PERSONNEL ONLY

The following is the process to manually step through the tool change operation in MDI.

**NOTE:** *Make sure you follow these steps in sequence to prevent damage to the ATC or machine.*

The proper sequence of a tool change and the respective M-codes are as follows:

1. T-code executes to move carousel to pending tool.
2. **M19** orient spindle.
3. **G75 FP=2 Z0**, moves z axis to tool change clearance position. (Tool change clearance position is stored in Axis MD Z1 parameter 30600 – FIX\_POINT\_POS[1]).
4. **M52** – Tool change carousel in position.
5. **M54** - Drawbar open to unclamp tool.
6. **G75 FP=1 Z0**, moves z axis to tool change height position. (Tool change height position is stored in Axis MD Z1 parameter 30600 – FIX\_POINT\_POS[0]).
7. **M55** Drawbar close to clamp tool in spindle.
8. **M53** Tool change carousel out position.

### 5.13 Setting Tool Change Height

---

#### PROCEDURE TO BE PERFORMED BY QUALIFIED PERSONNEL ONLY

The proper tool change height must be set for the ATC to perform correctly. The tool change height (machine coordinates from home position) is stored in parameter **MD30600**.

**NOTE:** To manually get the tool grab fingers of a carousel style ATC under the spindle you will need to disconnect the air from the machine and manually push the carousel toward the spindle. With the air disconnected you will be able to move the carousel in and out by hand.

- Refer to Section 4.1 for directions to access parameter screens.
- 1. Press **MENU SELECT**
- 2. Select **SETUP**
- 3. Select **MACHINE DATA**
- 4. Select **GENERAL MD**

**Caution! Take extreme care as changing these parameters will defeat built in safeties for TC collision!**

5. Select **SEARCH**
6. Type in **14512**
7. Select **OK**
8. There will be multiple **14512** parameters
  - **14512 [2]** is for carousel tool changers
9. You need to make a change to this parameter to turn the tool changer off
  - For carousel style tool changers subtract **1** from the current value
10. Cycle power to the machine leaving it off for at least 30 seconds
11. Insert a tool in the spindle
12. Now you need to get the tool grab component of the tool changer under the spindle
  - \*See note above on how to do this
13. To line up the “V” profile in the tool holder with the mating profile in the arm, use the handwheel on a fine setting to carefully move the head up or down
14. Remove air from machine
15. Manually move the carousel towards the spindle so the “v” profile in the tool holder needs to line up with the mating profile in the carousel fingers
  - Use a flashlight to get this alignment as close as possible
16. If “V” profile does not match
17. Record the **Z** axis machine position
18. Complete steps **1 – 8** to get back to setting the **14512** parameter
19. You need to change this parameter back to the previously noted values
  - For carousel style tool changers add **1** to the current value
20. Select **AXIS MD**
21. Select **AXIS +** until you are on **Axis Z**
22. Select **SEARCH**
23. Type in **30600**
24. Select **OK**
25. Set **30600[0]** equal to the value that you recorded in step **15**
26. Cycle power to the machine leaving it off for at least 30 seconds
27. Execute a manual tool change to verify proper function

### 5.14 Recovering from a Tool Change Failure

---

#### PROCEDURE TO BE PERFORMED BY QUALIFIED PERSONNEL ONLY

If the tool changer fails, you may get an alarm. This means that after 30 seconds of waiting, a function did not receive its proper finish signal. At this point, **do not E-stop or hit reset**. This can cause a tool to drop and possibly cause an injury to the operator.

- Locate the pneumatic solenoid for the carousel in/out function. You can do this by referring to the pneumatic system decal and labeled air lines.
- Once the proper solenoid is located, lock the carousel in the “in” position by pushing in the blue switch and turning it clockwise to keep it locked.
- At this point, the value of parameter **14512[2]** will need to be reduced by **1**. Use extreme caution as this will allow the Z-axis to move freely with the ATC in the “in” position.
- Cycle power leaving the machine off for at least 30 seconds.
- Execute an **M54** (drawbar on) to unclamp the tool from the spindle.
- The Z-axis can now be moved to the positive soft limit, clearing it from the tool in the tool changer.
- The solenoid can now be unlocked, which will return the carousel to the “out” position.
- Execute an **M55** (drawbar off) to clamp the tool in the spindle
- At this point the tool bin locations are potentially compromised. Refer to Section 5.15 to reset the tool bin locations.
- If there is a tool in the spindle and in the carousel and they crash into one another, hit E-stop to send the carousel to the out position. Refer to Section 5.15 to reset the tool bin locations.

### 5.15 Tool Carousel HOME Position and Tool Bin# Reset

---

To reset all the tool bin locations, follow this procedure:

1. Remove the tool from the spindle
2. In **MDI** command: Type in **M6T0** and press **CYCLE START**
3. Remove all new tools from the spindle
4. Go to command **M61** to index the carousel to bin #1
5. Go to tool table and select the **MAGAZINE** function.
6. Select **UNLOAD ALL** to remove the tools from the table.
7. Now select **TOOL LIST**. At this point all the current tool definitions are still in the table. They moved to the bottom below the highest tool number in your carousel.
8. You can now begin loading each tool definition up to the appropriate number that matches the physical location of the tool in the carousel. Do this by selecting **LOAD** and selecting a location number.

## 5.16 Spindle Orient Adjustment

### PROCEDURE TO BE PERFORMED BY QUALIFIED PERSONNEL ONLY

This procedure will outline how to adjust the spindle orient position when an M19 is commanded to perform a tool change. Read all instructions carefully and do not skip steps.

1. Put a tool in the spindle, make sure the carousel location in the load position( directly opposite the spindle) is empty.
2. In **MDI** clear out any previous commands and type in:  
**G75 FP=0 Z0**  
**M19**
3. Press **CYCLE START** to execute. Notice the direction the spindle goes in (Forward or Reverse)
4. Press **MENU SELECT**
5. **DIAGNOSTICS**
6. **AXIS DIAG**, (If you do not see key press “>” arrow key to see more buttons.
7. Press **SERVICE AXIS**
8. Use **Axis +** or **Axis -** key to display **AX4:MSP1/3.3.3/SPINDLE** see screen below:

Service axis/spindle		AX4:MSP1/3.3.3/SPINDLE	
Signal	Value	Unit	
Following error	-0.012	deg.	
Controller error	-0.012	deg.	
Contour deviation (axially)	-0.012	deg.	
Servo gain factor (calculated)	0.000	1000/min	
Active measuring system	1		
Status of measuring system 1	Active		
Status of measuring system 2	Park		
Pos. actual value measuring system1	257.812	deg.	
Pos. actual value measuring system2	0.000	deg.	
Position setpoint	257.800	deg.	
Abs. compens. value meas. system 1	0.000	deg.	
Abs. compens. value meas. system 2	0.000	deg.	
Compensation sag + temperature	0.000	deg.	
Act.speed value of active encoders	0.000	%	
Setpoint speed of drive	0.001	%	
Spindle speed set value programmed	0.000	rpm	
Spindle speed setpoint current	0.000	rpm	
Pos. offset to master axis/spindle act. value	0.000	deg.	
Pos. offset to master axis/spindle setpoint	0.000	deg.	

9. Press **RESET** and slowly turn the spindle in the direction the **M19** orient command turned in step 3, until the spindle keys line up with the ATC carousel key.
10. Remove the air pressure and push the ATC carousel under the spindle make sure the spindle key is lined up. While looking at the above screen turn the spindle CW and CCW. Note the max and minimum values of the Pos. actual value measuring system 1. Calculate the average of the two values. This is the new orient position.
11. Press **MENU SELECT**
12. Press **SETUP**
13. Press **MACH DATA**

14. Press AXIS SD ( you may have to press “>” to show additional buttons)
15. Use **Axis+** until spindle axis is displayed.
16. Scroll down to parameter **43240 \$SA\_M19\_SPOS**, this is the current orient position. Add the value you obtained in step 10 and input into this field.
17. Press reset and make sure the spindle orient goes to the correct position before doing a tool change

## 6.0 – MECHANICAL DRAWINGS

### 6.1 828 CONTROL ELECTRICAL PANEL LAYOUT

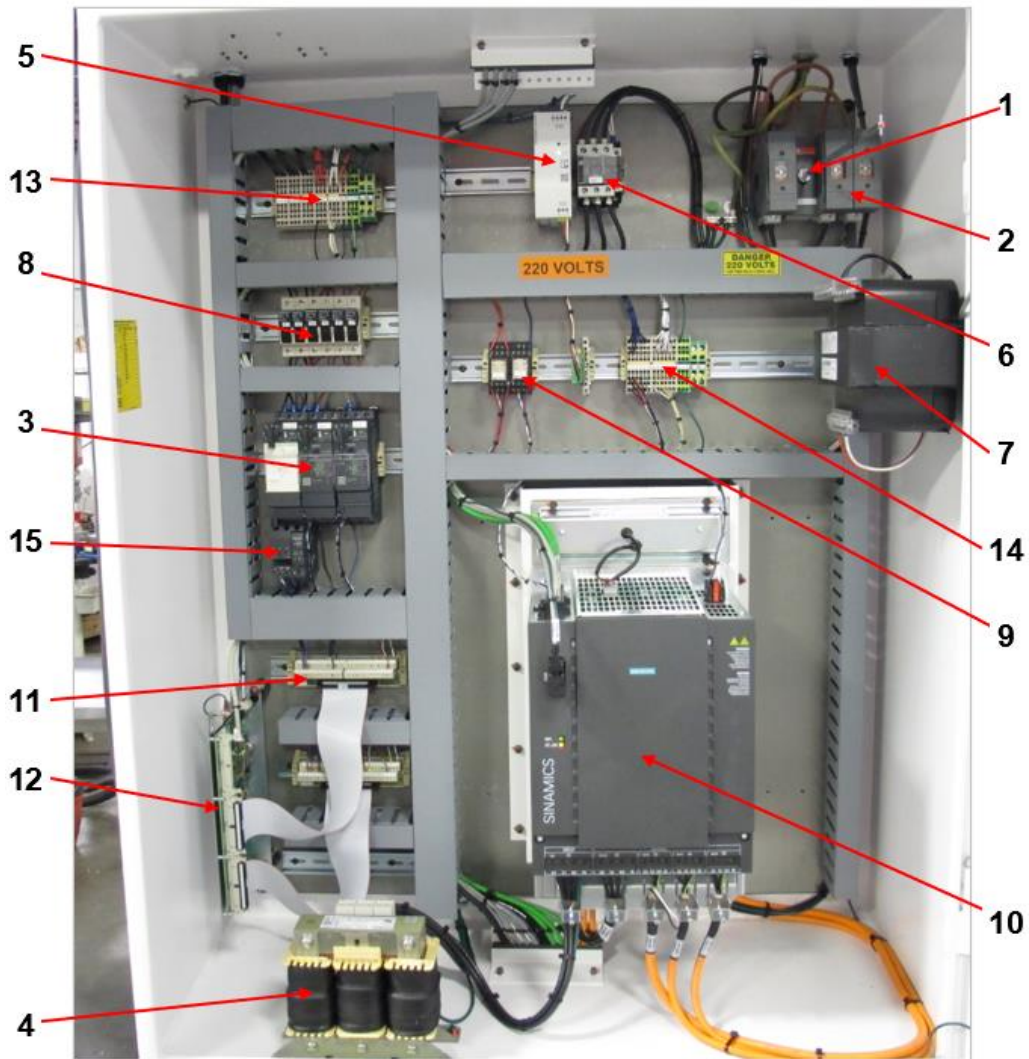

828 CONTROL ELECTRICAL PANEL – PARTS

REF	PART NO.	DESCRIPTION	PARTS NAME	QTY
1	SWT-5064	Main Disconnect		1
2	MSE-1912	Fuse Block		1
3		Motor Controller Overloads		1
4		Line Choke		1
5	MSE-2940	24 VDC POWER SUPPLY		1
6	MSE-1410	MC1 Magnetic Contactor		1
7	MSE-1610	Transformer		1
8		Fuse Panel		1
9		Contact Relays		1
10		Combi Drive		1
11		I/O Breakout Board		1
12	MSE-1330	I/O Card		1
13		Terminal Block		1
14		Terminal Block		1

## 6.2 828 FRONT CONTROL PANEL LAYOUT



REF	PART NO.	DESCRIPTION	PARTS NAME	QTY
1	MON-4378	Siemens Monitor NCU		1
2	CMB-3202	Siemens Control Panel		1
3	MSM-8210	Keys (3)		1 set
4	SWT-6210	E-Stop w/ Contact Block		1

### 6.3 828 3-HANDWHEEL OPERATOR CONSOLE (OPTION)



REF	PART NO.	DESCRIPTION	PARTS NAME	QTY
1	MON-4378	Siemens Monitor NCU		1
2	CMB-3202	Siemens Control Panel		1
3	SWT-6210	E-Stop w/ Contact Block		1
4	70131528	Fine / Course Switch		1
5	ASY-6192	Handwheel (3-Panel)		3
6	MSM-8210	Keys (3)		1 set
7	SWT-5052	Joystick Switch		1



**6.4 MACHINE BASE AND COLUMN**

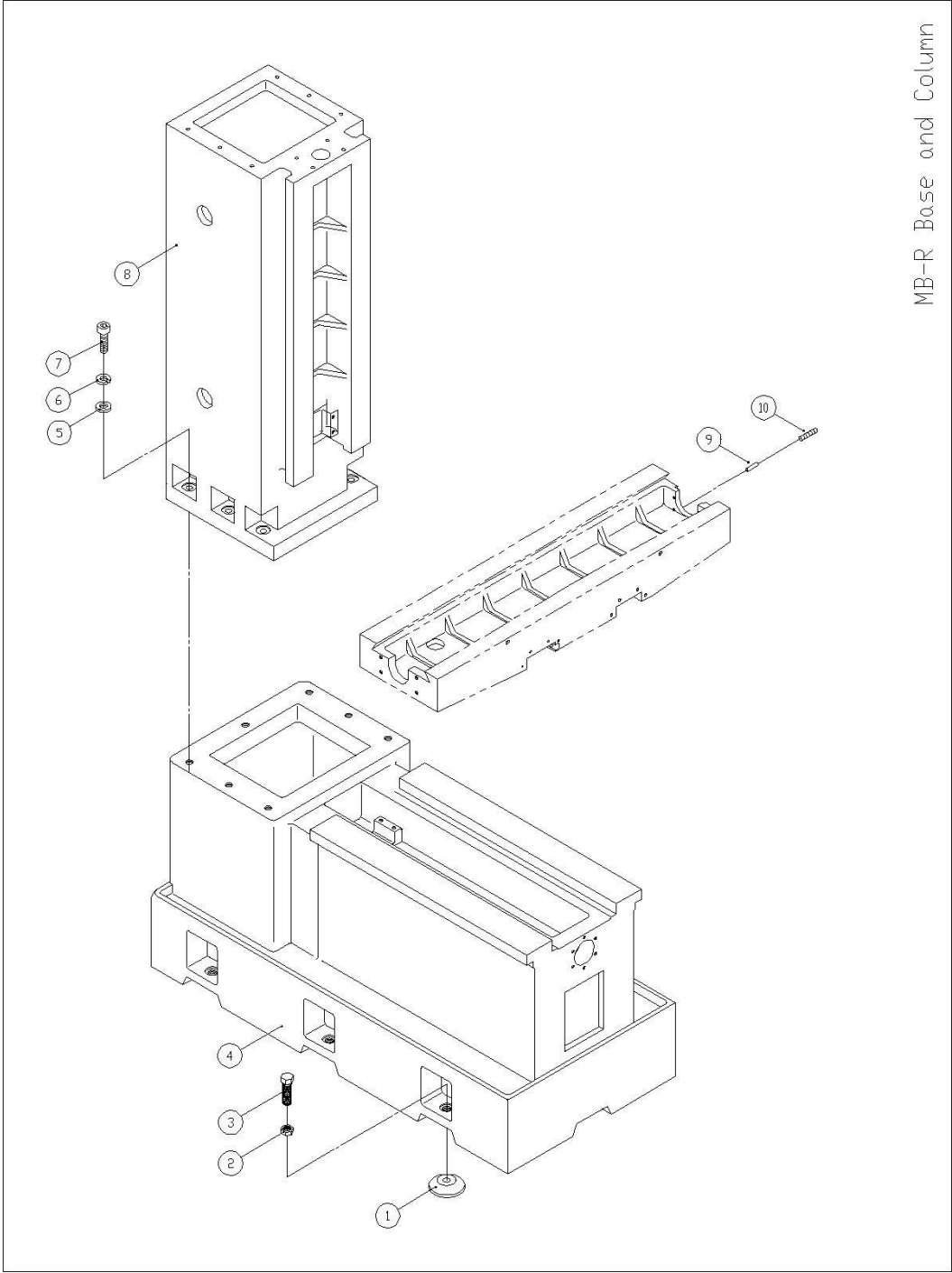

MB-R Base and Column

<b>MODEL:</b> <b>MB-R</b>	<b>BASE &amp; COLUMN</b>			
<b>ITEM #</b>	<b>PART # MB</b>	<b>PART NAME</b>	<b>QTY.</b>	<b>SPECIFICATION</b>
1		LEVELING PAD	6	
2		LEVELING BOLT LOCK NUT	6	M24 X 1.5
3		LEVELING BOLT	6	M24 X 1.5
4		BASE CASTING	1	
5		FLAT WASHER	7	W-M20
6		SPRING WASHER	7	SW-M20
7		SOCKET HEAD CAP SCREW	7	M20 X 80L
8		COLUMN	1	
9		BLOCK	1	
10		SET SCREW	1	W1/2-12

**6.5 MACHINE COUNTERBALANCE ASSEMBLY**

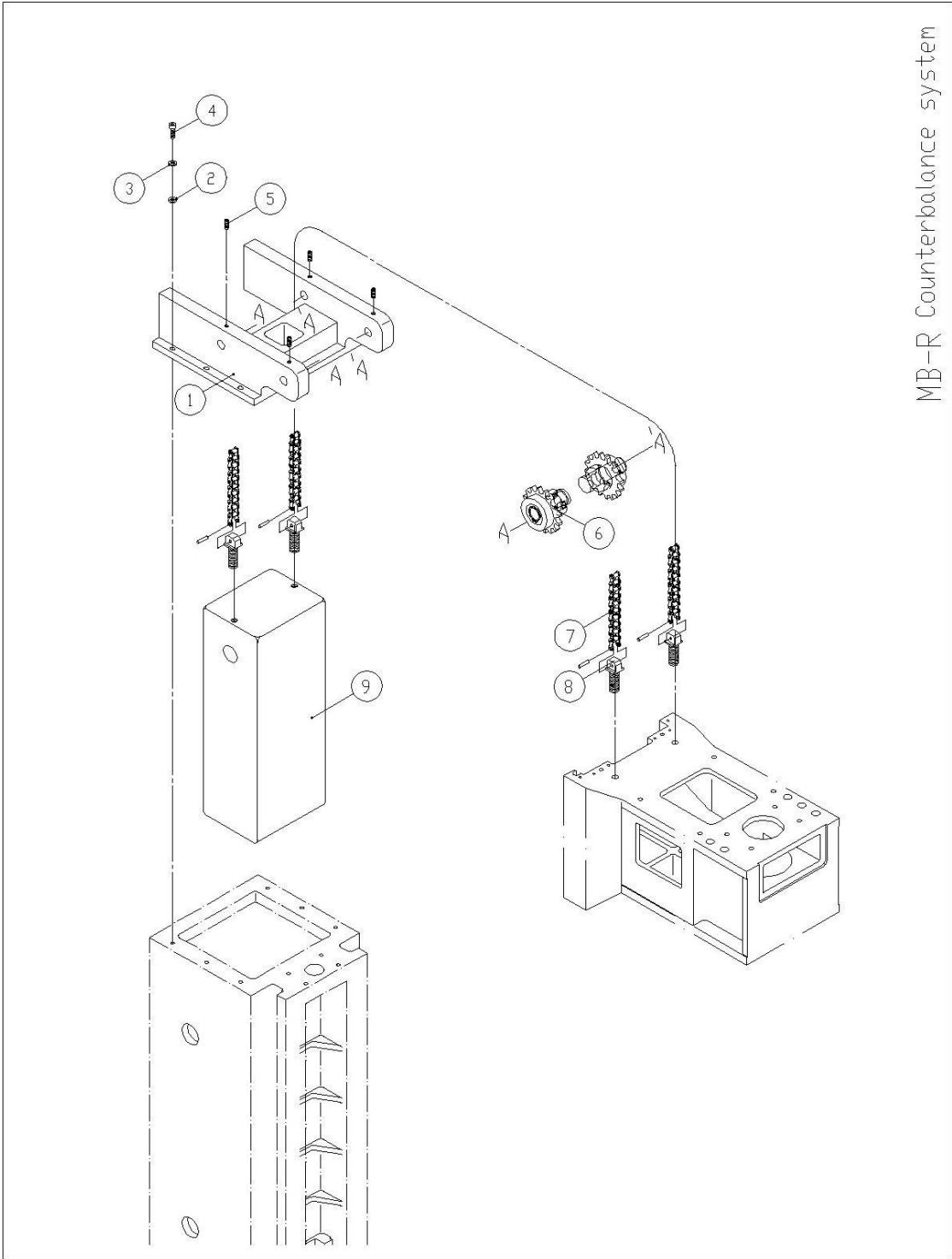

MB-R Counterbalance system

<b>MODEL:</b> <b>MB-R</b>	<b>COUNTERBALANCE</b>			
<b>ITEM #</b>	<b>PART #</b>	<b>PART NAME</b>	<b>QTY.</b>	<b>SPECIFICATION</b>
1		CHAIN CASTING	1	
2		WASHER	6	W-M10
3		SPRING WASHER	6	SW-M10
4		SOCKET HEAD CAP SCREW	6	M10 X 40L
5		SET SCREW	4	M10 X 16L
6		CHAIN CASTING SPROCKET ASSEMBLY	1	
7	BEN-1800	CHAIN	1 SET	#50
8		CHAIN BOLT	4	
9		COUNTERWEIGHT	1	

**6.6 MACHINE HEAD ASSEMBLY**

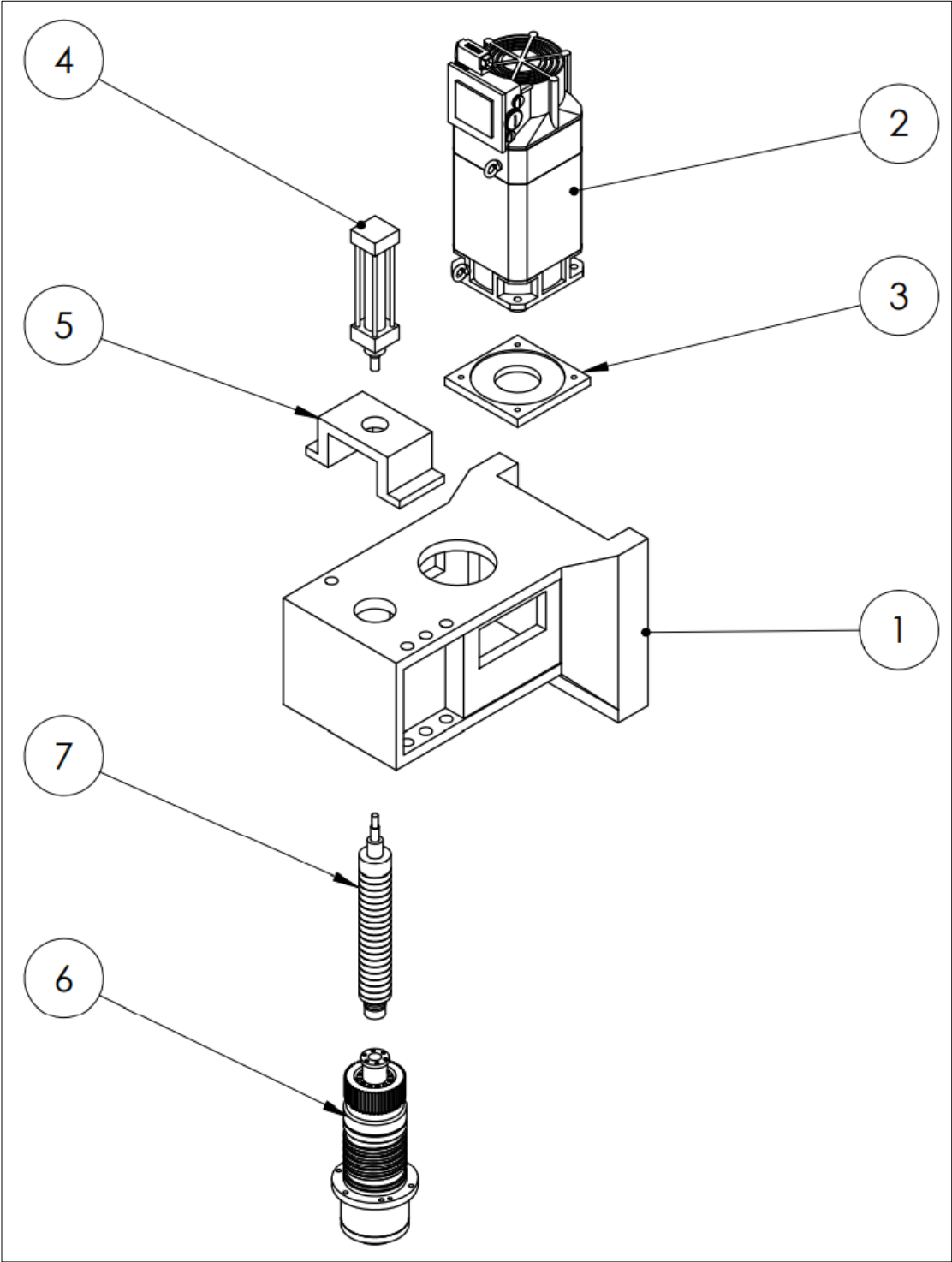

Item No.	Part Number	Description	Q'ty
1	Ram Casting		1
2	Spindle Motor		1
3	Spindle Motor Plate		1
4	Drawbar Actuator		1
5	Drawbar Actuator Mount		1
6	Spindle Cartridge		1
7	Drawbar Assembly		1

**6.7 MACHINE TABLE ASSEMBLY**

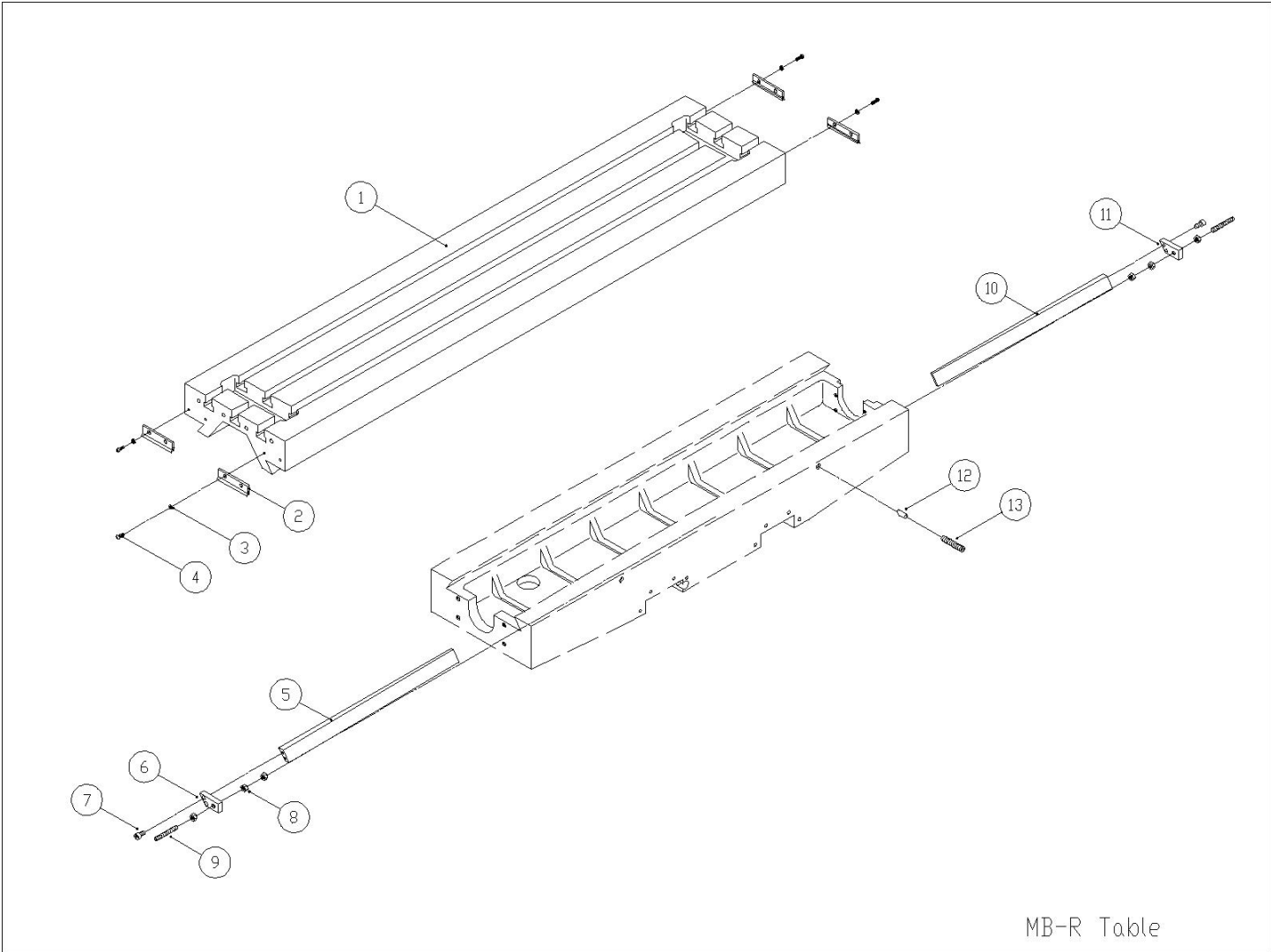

MB-R Table

<b>MODEL: MB-R</b>	<b>TABLE</b>			
<b>ITEM #</b>	<b>PART #</b>	<b>PART NAME</b>	<b>QTY.</b>	<b>SPECIFICATION</b>
1		TABLE	1	
2	POL-1141 (MB-10)	WIPER SET X, Y & Z	1	
2	POL-1270 (MB-14)	WIPER SET X, Y & Z	1	
2	POL-1460 (MB-16)	WIPER SET X, Y & Z	1	
3		WASHER	8	W-M6
4		WIPER SCREW	8	M6 X 12L
5		LEFT GIB	1	
6		FIXED PLATE (a)	1	
7		SOCKET HEAD CAP SCREW	4	M6 X 16L
8		HEX NUT	6	N-M8
9		SET SCREW	2	M8 X 80L
10		RIGHT GIB	1	
11		FIXED PLATE (b)	1	
12		BLOCK	2	
13		SET SCREW	2	W1/2-12



**6.8 MACHINE SADDLE ASSEMBLY**

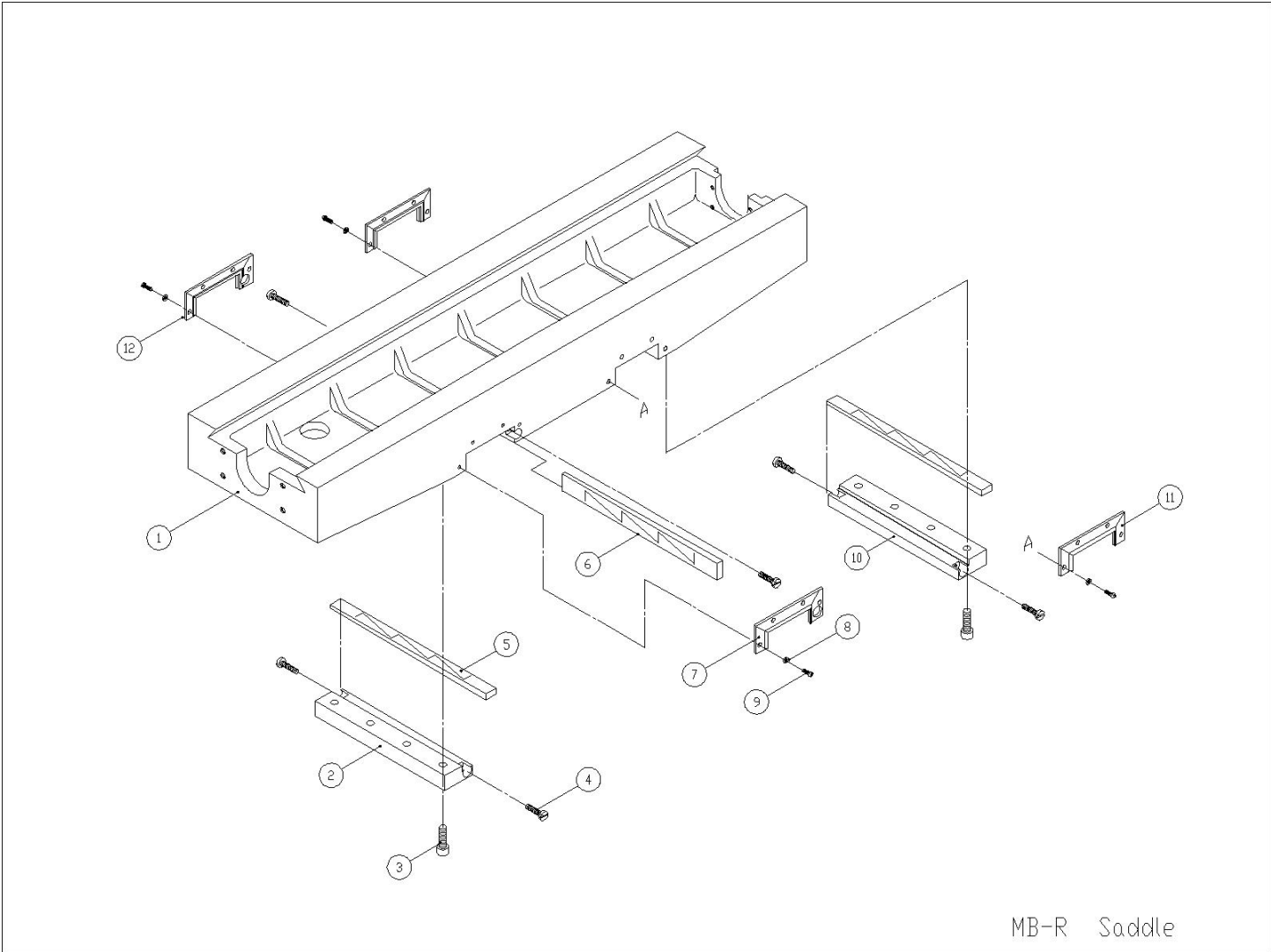

<b>MODEL: MB-R</b>	<b>SADDLE</b>			
<b>ITEM #</b>	<b>PART #</b>	<b>PART NAME</b>	<b>QTY.</b>	<b>SPECIFICATION</b>
1		SADDLE	1	
2		LEFT GIB BLOCK	1	
3		SOCKET HEAD CAP SCREW	8	M12 X 35L
4		GIB SCREW	6	
5		LOWER GIB	2	
6		SIDE GIB	1	
7	POL-1141 (MB-10)	WIPER SET X, Y & Z	1	
7	POL-1270 (MB-14)	WIPER SET X, Y & Z	1	
7	POL-1460 (MB-16)	WIPER SET X, Y & Z	1	
8		WASHER	16	W-M6
9		WIPER SCREW	16	M6 X 12L
10		RIGHT GIB BLOCK	1	
11		RIGHT WIPER	2	
12		LEFT REAR WIPER	1	

**6.9 MACHINE X-AXIS ASSEMBLY**

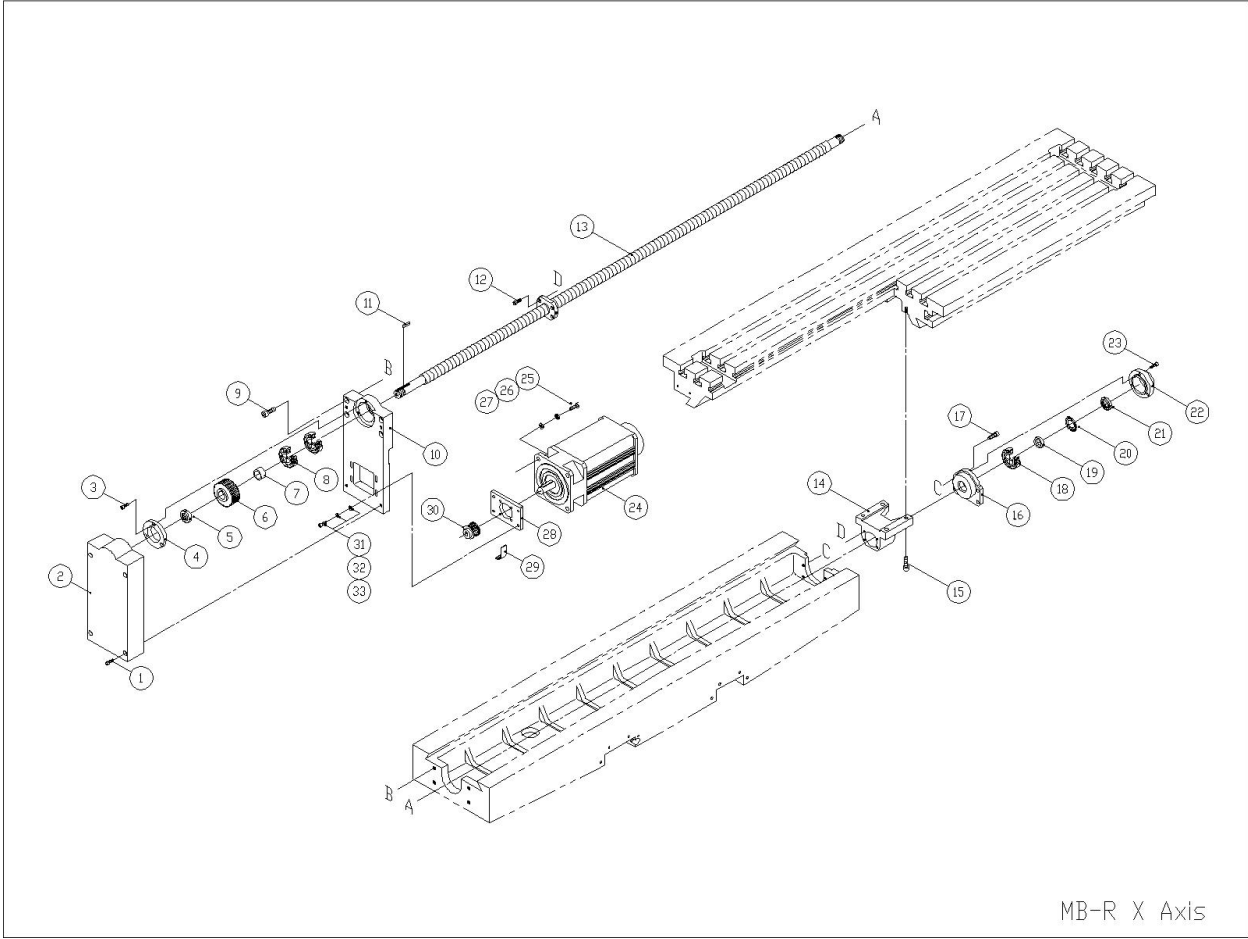

<b>MODEL: MB-R</b>	<b>X-AXIS</b>			
<b>ITEM #</b>	<b>PART #</b>	<b>PART NAME</b>	<b>QTY.</b>	<b>SPECIFICATION</b>
1		SOCKET HEAD CAP SCREW	4	M8 X 65L
2		X-AXIS MOTOR COVER	1	
3		SOCKET HEAD CAP SCREW	3	M6 X 16L
4	POL-1244	LEFT END CAP	1	
5		SPANNER NUT	1	YSRM25XP1.5
6	POL-1054	BALLSCREW PULLEY	1	
7		LEFT BEARING SPACER	1	
8	POL-1040	THRUST BEARING	1 SET	25TAC62BDF
9		SOCKET HEAD CAP SCREW	4	M10 X 30L
10		X-AXIS MOTOR BRACKET	1	
11		KEY	1	6X6X27L
12		SOCKET HEAD CAP SCREW	4	M6 X 20L
13	POL-1147 (MB-10R)	X-AXIS BALLSCREW	1	
13	POL-1348 (MB-14R)	X-AXIS BALLSCREW	1	40MM
13	POL-1472 (MB-16R)	X-AXIS BALLSCREW	1	40MM
14		X-AXIS BALLSCREW YOKE	1	
15		SOCKET HEAD CAP SCREW	4	M10 X 30L
16		RIGHT BEARING HOUSING	1	
17		SOCKET HEAD CAP SCREW	4	M8 X 20L
18	POL-2140	RADIAL BEARING	1	6305
19		RIGHT BEARING SPACER	1	
20		SUN WASHER	1	AW-05
21		SPANNER NUT	1	AN-05
22		RIGHT END CAP	1	
23		SOCKET HEAD CAP SCREW	3	M6 X 20L
24	MTR-4454	X-AXIS MOTOR	1	
25		SOCKET HEAD CAP SCREW	4	
26		SPRING WASHER	4	
27		WASHER	4	
28		X-AXIS MOTOR PLATE	1	
29	630-5M-25	X-AXIS BELT	1	
30		X-AXIS MOTOR PULLEY	1	
31		SOCKET HEAD CAP SCREW	4	
32		SPRING WASHER	4	
33		WASHER	4	

**6.10 MACHINE Y-AXIS ASSEMBLY**

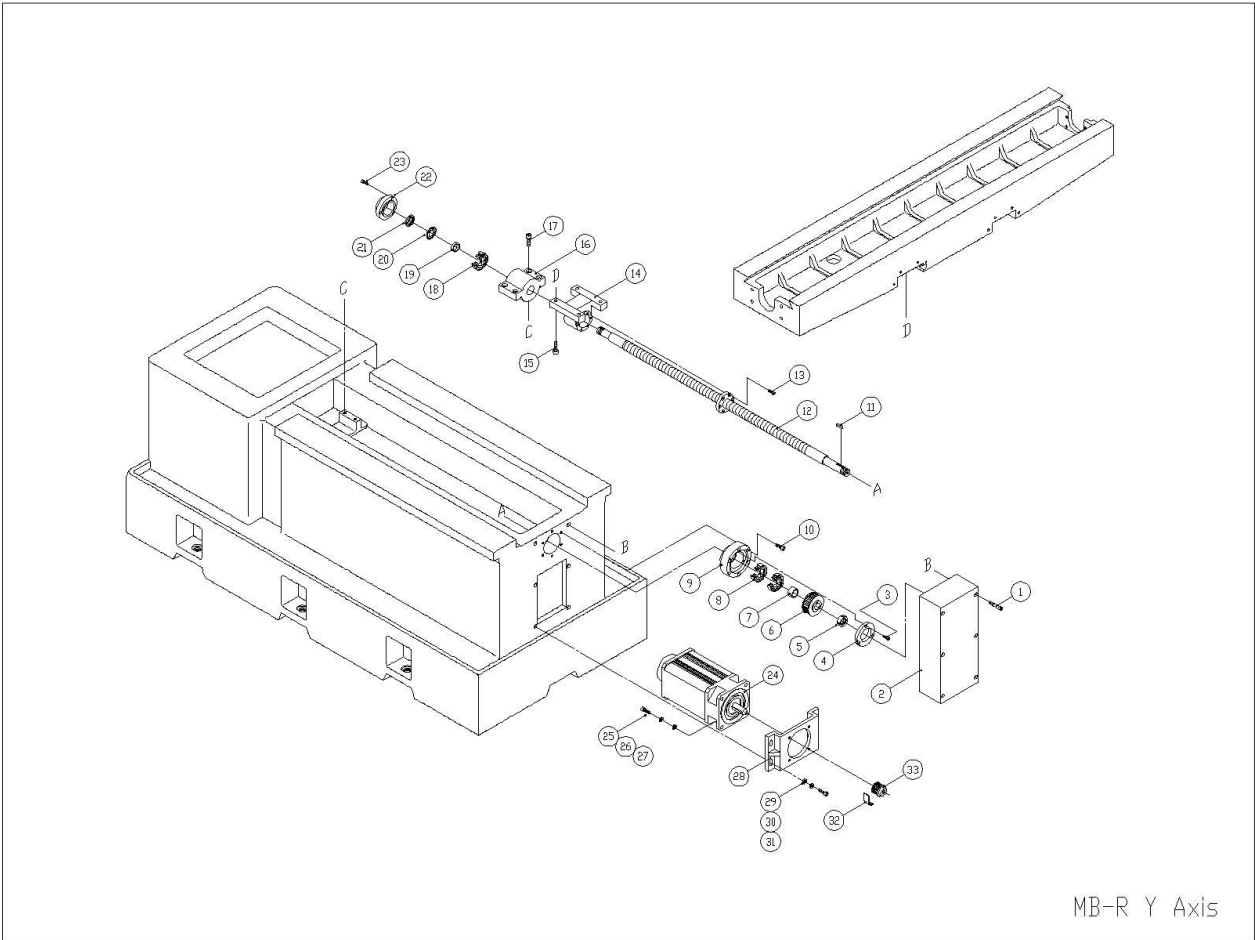

<b>MODEL: MB-R</b>	<b>Y-AXIS</b>			
<b>ITEM #</b>	<b>PART #</b>	<b>PART NAME</b>	<b>QTY.</b>	<b>SPECIFICATION</b>
1		SOCKET HEAD CAP SCREW	6	M6 X 65L
2		Y-AXIS MOTOR COVER	1	
3		SOCKET HEAD CAP SCREW	3	M6 X 16L
4		FRONT END CAP	1	
5		SPANNER NUT	1	YSRM25XP1.5
6	POL-1054	BALLSCREW PULLEY	1	
7		FRONT BEARING SPACER	1	
8	POL-1040	THRUST BEARING	1 SET	25TAC62BDF
9		FRONT BEARING HOUSING	1	
10		SOCKET HEAD CAP SCREW	4	M8 X 40L
11		KEY	1	6X6X27L
12	POL-1148 (MB-10R)	Y-AXIS BALLSCREW	1	
12	POL-1474 (MB -14/16R)	Y-AXIS BALLSCREW	1	40MM
13		SOCKET HEAD CAP SCREW	6	M6 X 20L
14		Y-AXIS BALLSCREW YOKE	1	
15		SOCKET HEAD CAP SCREW	4	M10 X 30L
16		BACK BEARING HOUSING	1	
17		SOCKET HEAD CAP SCREW	4	M8 X 25L
18	POL-2140	RADIAL BEARING	1	6305
19		BACK BEARING SPACER	1	
20		SUN WASHER	1	AW-05
21		SPANNER NUT	1	AN-05
22		BACK END CAP	1	
23		SOCKET HEAD CAP SCREW	3	M6 X 20L
24		Y-AXIS MOTOR	1	
25		SOCKET HEAD CAP SCREW	4	
26		SPRING WASHER	4	
27		WASHER	4	
28		Y-AXIS MOTOR MOUNT	1	
29		SOCKET HEAD CAP SCREW	4	
30		SPRING WASHER	4	
31		WASHER	4	
32	630-5M-25	Y-AXIS BELT	1	
33		Y-AXIS MOTOR PULLEY	1	

# 6.11 MACHINE Z-AXIS ASSEMBLY

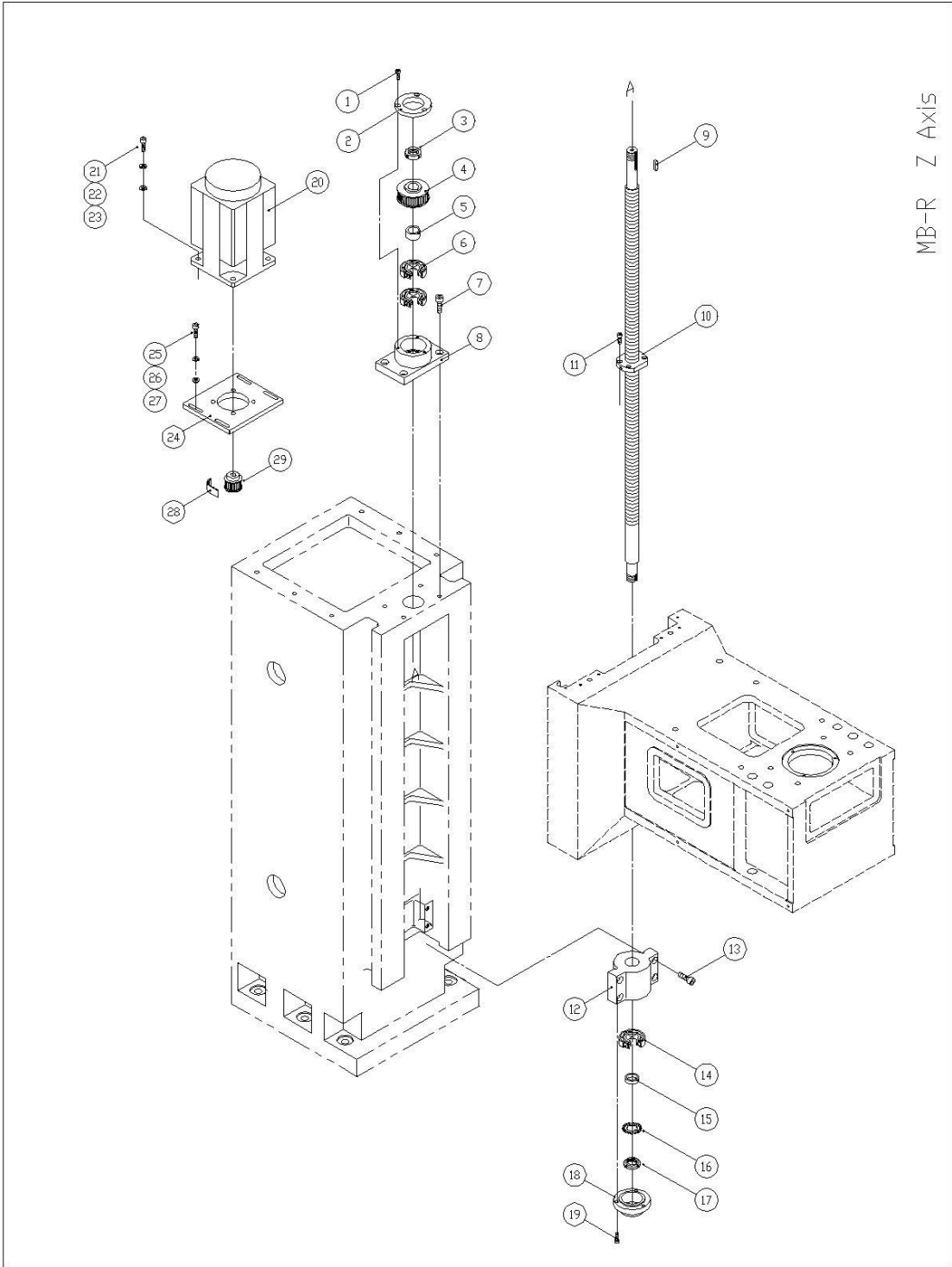

MB-R Z Axis

<b>MODEL: MB-R</b>	<b>Z-AXIS</b>			
<b>ITEM #</b>	<b>PART #</b>	<b>PART NAME</b>	<b>QTY.</b>	<b>SPECIFICATION</b>
1		SOCKET HEAD CAP SCREW	3	M6 X 16L
2		TOP END CAP	1	
3		SPANNER NUT	1	YSRM25XP1.5
4		BALLSCREW PULLEY	1	
5		TOP BEARING SPACER	1	
6	POL-1040	THRUST BEARING	1 SET	25TAC62BDF
7		SOCKET HEAD CAP SCREW	4	M10 X 30L
8		TOP BEARING HOUSING	1	
9		KEY	1	6X6X27L
10	POL-1149 (MB-10R)	Z-AXIS BALLSCREW	1	
10	POL-1372 (MB-14/16R)	Z-AXIS BALLSCREW	1	40MM
11		SOCKET HEAD CAP SCREW	4	M6 X 20L
12		Z-AXIS BALLSCREW YOKE	1	
13		SOCKET HEAD CAP SCREW	4	M8 X 30L
14	POL-2140	RADIAL BEARING	1	6305
15		BOTTOM BEARING SPACER	1	
16		SUN WASHER	1	AW-05
17		SPANNER NUT	1	AN-05
18		BOTTOM END CAP	1	
19		SOCKET HEAD CAP SCREW	3	M6 X 20L
20	MTR-4456	Z-AXIS MOTOR	1	
21		SOCKET HEAD CAP SCREW	4	
22		SPRING WASHER	4	
23		WASHER	4	
24		Z-AXIS MOTOR PLATE	1	
25		SOCKET HEAD CAP SCREW	4	
26		SPRING WASHER	4	
27		WASHER	4	
28	640-5M-25	Z-AXIS BELT	1	
29		Z-AXIS MOTOR PULLEY	1	